



A10-TX
Digital Transmitter
— User Guide —



Copyright / Doc Rev History Info

Model A10-TX only. See separate documentation for A10-TX-US model.

Copyright © 2018 Audio Ltd. All rights reserved. | www.audioltd.com

7 Century Court, Tolpits Lane, Watford WD18 9RS, UK | info@audioltd.com

Revision	Date	Description
1A	Dec 2017	Initial Publication
1B	Feb 2018	Added note re: Bluetooth remote range

Table of Contents

Copyright / Doc Rev History Info	2	Audio Level Control	11
Table of Contents	2	Antennas	11
Overview	3	Recording	11
Key Features	3	Record Control	11
System Quickstart	3	File Storage	12
At the Receiver	3	File Conversion .MIC to .WAV	12
At the Transmitter	3	Timecode and Time-of-Day Clocks	12
At the Receiver	4	Time-of-Day Clock	12
Connectors, Controls Description	5	Timecode Clock	12
Powering	6	Timecode Output	13
Main Display	6	Remote Control	13
Menu Control and Menu Selections	7	Firmware Updates	14
Main Menu	7	Specifications	14
Audio Setup Menu	8	Input Connector Wiring Diagram	15
Record / TC Menu	8	Battery Runtime Chart	15
Settings Menu	9	Certifications	15
System Menu	9	Industry Canada Conformity	15
Basic Operation	10	FCC Conformity	16
Frequency Selection	10	Minimize RF Exposure	16
Channel, Sub Channel, Frequency	10	Frequency Tables	17
Audio Input and Control	10	X Frequencies (6 MHz Per TV Channel)	17
Lavalier Microphones	10	Y Frequencies (7 MHz Per TV Channel)	18
Balanced Microphones with Phantom	11	Z Frequencies (8 MHz Per TV Channel)	19
Line-Level Sources	11	Channel Assignments by Region	19

Overview

The A10 Digital Wireless System meets the demanding requirements of the professional sound community engaged in film and television production. It offers superb audio and RF performance.

The digital RF transmission of the A10 system allows the user to operate up to 20 channels in an 8 MHz TV channel, maximising spectrum efficiency without compromising on range, audio quality or latency.

The A10-TX transmitter incorporates Audio Ltd's proprietary digital modulation scheme whilst maintaining the high audio quality that Audio Ltd has become renowned for, and with extremely low end-to-end latency of 2 mS.

The A10-TX has an intuitive menu system allowing the user to become familiar with settings within a few minutes of turning it on.

Key Features

- Low-noise, studio-grade balanced input for microphones and line level signals with analogue limiter and phantom power.
- Fully digital RF transmission
- Ultra-accurate timecode generator jam synched from external clocks.
- Integrated digital recorder records to removable microSD cards. External conversion is required to turn data files into WAV files using the free Mic2Wav app for Mac or Windows.
- Simultaneous wireless transmission and recording
- Remote controllable over Bluetooth® using the A10-TX Remote app for Android and iOS.
- Powered by easy-to-access AA batteries.

System Quickstart

The A10 Digital Wireless System is easy to use. Follow the steps below for basic setup and operation.

At the Receiver

1. Fit the included straight and right-angled antennas to the A10-RX receiver.
2. Connect the receiver to a power source. It will immediately power on.
3. Using the scanning tool in the Selection menu find an available open frequency. If multiple wireless systems are in use, make certain to keep frequencies least 400 kHz apart.
4. Connect the audio output from channel 1, channel 2, or both to an audio input on a mixer, recorder, camera, or PA system.
5. Ensure that the receiver audio output type and level are set based on the input type.

At the Transmitter

1. Attach the straight antenna to the A10-TX.
2. Attach an audio source to the 3-pin LEMO input connector.
3. Insert AA batteries into the A10-TX battery compartment and power on the unit with the red On/Off button.
4. Set the audio input type to set to match the connected input.
5. Set the transmitting frequency on the A10-TX match the frequency set on the A10-RX receiver channel.
6. Adjust the audio gain according to your environment and source, taking care not to overload the signal. This is indicated by a red LED.

At the Receiver

1. Confirm that the blue channel power LED is solid blue.
2. Confirm that the RF status LEDs and display indicate good RF strength.
3. Confirm that the audio level at the receiver corresponds to the audio connected to the A10-TX input.
4. The system is now ready for use.

Connectors, Controls Description

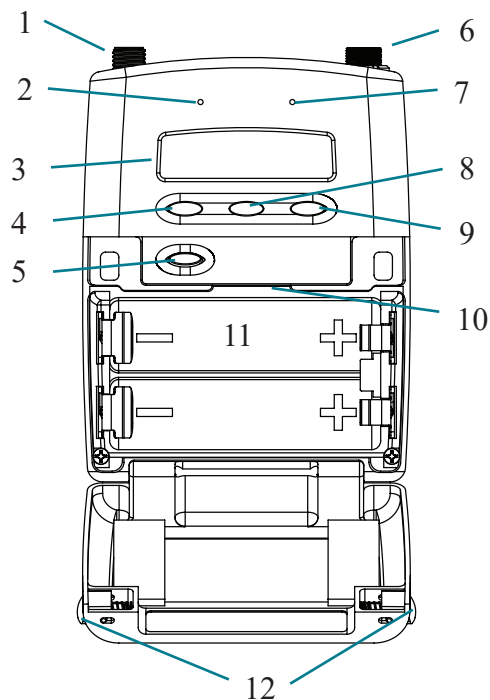

Figure 1: A10-TX transmitter with open battery compartment

1 -Antenna Socket

SMA connector, 50 ohm, connects to included 1/4-wave whip antenna.

2 -Power LED

Blue LED illuminates when unit is powered on and screensave is active. Solid blue LED can be turned off in the Menu. The LED flashes blue when unit is in Sleep mode.

3 -Display

OLED screen. Screen automatically turns off during operation for battery savings.

4 -Left Button

Moves selection in menu to the left, or decrements values.

5 -Power Button

Press to power on the unit. Press and hold to power down the unit.

6 -Audio Input Connector

Balanced LEMO-3 connector. Accepts multiple audio input types including unbalanced lavalier, balanced microphone, balanced line.

Also used for timecode input and output.

7 -Input Overload LED

Red LED illuminates when clipping occurs.

8 -Menu Button

Enters the menu selection. Also used to select options in the menu.

9 -Right Button

Moves menu selection to the right, or increments values.

10 - microSD Card Slot

The card slot is used to record files and load firmware updates on the unit.

11 - Battery Tray

Accepts two AA LR6 batteries.

12 - Battery Door Latch

Press both latches to open the battery door.

Powering

The A10-TX is powered by two AA (LR6) batteries. For the longest runtime, use Lithium primary cells. The transmitter also accepts alkaline primary and Nickel Metal Hydride rechargeable batteries. Select the battery type used in the menu to ensure that the battery condition is indicated accurately in both the transmitter display and receiver.

1. Open the battery compartment by simultaneously pressing both mechanical releases of the battery door latch. (See Figure 1.)
2. Insert two fresh AA type (LR6) batteries. Note correct battery polarity.
3. Momentarily press the red On/Off button. The blue power LED will light and the display will illuminate. The transmitter is now powered on.
4. To turn the transmitter off, press and hold the red button until the “turning off” progress bar completes and the unit goes dark.

Main Display

After powering on the A10-TX the display shows the following.

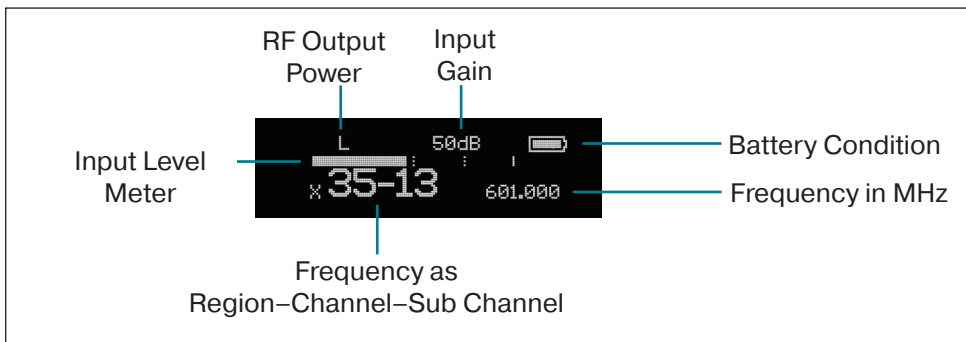

- **RF Output Power** - three power levels are indicated, **Low** (10 mW), **Medium** (20 mW), **High** (50 mW)
- **Input Gain** - gain applied to the input source, in dB
- **Battery Condition** - shows the battery voltage level of the transmitter batteries, five-segments
- **Frequency in MHz** - the transmitting frequency is shown
- **Frequency in Region-Channel-Sub Channel** - the transmitting frequency is shown in region, channel, and sub channel.

↳ *X, Y, and Z regions are selected by the TV Channel Map setting.*

- **Input Level Meter** - shows audio input signal level

Press the Left button, to view the name of the transmitter. The serial number of the transmitter is the default name of the transmitter. The transmitter name may be changed via the A10-TX Remote app.









SA0117268002

By pressing the Right button, the user can view the recording status, which displays the current file name, time elapsed, time remaining, timecode and current frame rate.

Menu Control and Menu Selections





The A10-TX transmitter is controlled through its menu. Enter the menu via the centre Menu button. Once in the menu, the Left and Right buttons toggle among options, and the Menu button makes the selection.

Main Menu









Selections	Icon	Description	Options
Exit		Returns to the main display screen.	
Frequency Selection		Sets the transmitter's frequency. Frequency selection and channel increments change based on the region of operation the unit is set.	<ul style="list-style-type: none"> • TV Channel Increments • Sub Channel Increments • Frequency Increments in 25 kHz steps
Audio Gain		Controls the gain range of the audio input. Gain range is input type dependent. Gain control is in 1 dB increments.	<ul style="list-style-type: none"> • Lav: 0 dB to +40 dB • Line Setting: -10 to 16 dB • Mic setting: 16 to 40 dB w/20dB pad • Mic setting: 36 to 60 dB
Audio Setup		Enters the Audio Setup sub-menu.	<ul style="list-style-type: none"> • Low Cut • Limiter • Lav / Mic / Line
Record / TC		Enters the Record / TC sub-menu.	<ul style="list-style-type: none"> • Record • File Info • TX / Record Mode • Timecode • Frame Rate
Privacy		<p>Activates transmission privacy with a four-number key set on the transmitter and receiver. When active, the receiver must be set to the corresponding key for audio to pass.</p> <p>New Key option generates a key. The key symbol is displayed on main default screen when privacy is active.</p>	<ul style="list-style-type: none"> • New Key - generates new key • Off - encryption cleared, set to ----, not active
Settings		Enters the Setting sub-menu.	<ul style="list-style-type: none"> • Bluetooth • RF Power • Brightness • Battery Type • Blue LED • TV Ch Map
System		Enters the System sub-menu.	<ul style="list-style-type: none"> • Sleep • Lock Menu • Set Time/Date • Format Card • Restore • Info • Update Firmware

A10-TX User Guide

Audio Setup Menu







Selections	Icon	Description	Options
Exit		Returns to the main menu.	
Low Cut		Activates a low frequency cut filter to the audio input. 18 dB/octave	<ul style="list-style-type: none"> • Off • 40 Hz • 60 Hz • 80 Hz • 100 Hz • 200 Hz
Limiter		The limiter reduces peak levels of the analogue audio input before digital conversion to prevent audio overload. The recommended setting is On.	<ul style="list-style-type: none"> • On • Off
Lav / Mic / Line		Selects the input type at the LEMO-3 connection.  <i>For Mic/Line, the AC-BAL-XLR accessory is required.</i>	<ul style="list-style-type: none"> • Lav • Mic • Line • P48 - mic level with 48 V phantom • P12 - mic level with 12 V phantom

Record / TC Menu









Selections	Icon	Description	Options
Exit		Returns to the main menu.	
Record		Select Record to enter Record mode (This begins recording). The Record status is remembered across sleep and power cycles.	
File Info		Shows important information about the file being recorded.	<ul style="list-style-type: none"> • Time Elapsed • Time Remaining • Timecode • File Name
TX / Record Mode		Select the operational mode of the A10-TX.	<ul style="list-style-type: none"> • TX/Rec - simultaneous wireless transmission and recording • RecOnly - recording function only
Timecode		Enter Timecode menu. Timecode values from either the attached external timecode generator or the internal generator are shown.  <i>Whilst in this menu, wireless transmission is suspended, and timecode may be sent via AC-TCBNC-OUT or AC-TCLEMO accessories.</i>	<ul style="list-style-type: none"> • Time of Day • External • Jam - applies external timecode to the internal generator.  <i>Jamming to an external timecode source requires the AC-TCBNC-IN or AC-TCLEMO accessories.</i>
Frame Rate		Sets the frame rate of the timecode clock. Select a rate that matches the incoming timecode rate.  <i>Rejam is required after setting frame rate.</i>	<ul style="list-style-type: none"> • 23.98 • 24 • 25 • 29.97 • 29.97 DF • 30 • 30 DF

A10-TX User Guide

Settings Menu

Selections	Icon	Description	Options
Exit		Returns to the main menu.	
Bluetooth		Toggles Bluetooth On or Off. Bluetooth offers external control of the A10-TX via the A10-TX Remote App (for iOS or Android).	<ul style="list-style-type: none"> • On • Off
RF Power		Sets the RF output power of the transmitter.	<ul style="list-style-type: none"> • Low - 10 mW • Med - 20 mW • High - 50 mW
Brightness		Sets the brightness of the OLED screen	Five increments, 1–5, 5 is brightest
Battery Type		For accurate display of battery condition on the transmitter and receiver select the battery type from the available options.	<ul style="list-style-type: none"> • Alkaline • NiMH • Lithium
Blue LED		If set to On, the LED illuminates blue when powered on and screensaver is active.	<ul style="list-style-type: none"> • On • Off
TV Ch Map		Selects the TV channel spacing in MHz to ensure channel selection corresponds to a specific geographic region. See frequency chart.	<ul style="list-style-type: none"> • X – 6 MHz • Y – 7 MHz • Z – 8 MHz

System Menu

Selections	Icon	Description	Options
Exit		Returns to the main menu.	
Sleep		When selected, the A10-TX goes into low-power Sleep mode. The blue LED flashes when the unit is in a sleep state. The unit returns to normal power operation when any button is pressed or the transmitter is activated from the A10-TX Remote App.	<ul style="list-style-type: none"> • Sleep
Lock Menu		Activates a button lock to prevent unintentional changes to menu selections.	<ul style="list-style-type: none"> • Unlock • Lock
Set Time / Date		Sets the time and date of the realtime clock. This value is applied to any recorded files.	
Format Card		Deletes all files and data present on the inserted microSD card and prepares it for new recordings.	OK - begins formatting process.
Restore		The restore function allows the user to reset the A10-TX to the factory default settings.	
Info		Shows numerous attributes of the transmitter.	<ul style="list-style-type: none"> • Serial Number • Firmware Revision • Frequency Band
Update (Firmware)		Updates the firmware of the transmitter using a firmware .PRG file on the microSD card.	

Basic Operation

Frequency Selection

The A10 Digital Wireless System operates in the UHF frequency band from 470 to 694 MHz. There are three models (two in some geographic markets) of the A10-TX transmitter to cover this frequency range.

Multiple A10 Digital Wireless systems can be used simultaneously on nearby adjacent frequencies without worry of intermodulation interference since the A10 Digital Wireless System and its digital RF transmission is inherently immune to intermodulation. Systems can be used together when separated by at least 400 kHz. Use the scan tool on the A10-RX receiver to search for available frequencies.

↳ *When using A10 Digital Wireless systems in conjunction with analogue RF systems, an intermodulation plan needs to be addressed for analogue receivers.*

Channel, Sub Channel, Tune

To simplify frequency selection, frequencies are divided into channels and sub channels. Frequencies corresponding to channels and sub channels depend on the TV Channel Mapping selected in the Systems menu. Three options are available, 6, 7, and 8 MHz spacing, X, Y, and Z respectively. These three settings generally correspond to three main geographic regions, USA, Australia/New Zealand, and Europe, respectively.

- **Channel** - corresponds to broadcast television channels used in geographic regions. Depending on the selected channel mapping, channels cover 6, 7, or 8 MHz.
- **Sub Channel** - channels are divided in 400 kHz increments called sub channels to speed up frequency selection. The number of sub channels depends on the channel mapping selected.
- **Tune** - specific frequencies within the transmitter's tuning range can be selected in 25 kHz increments.

To change TV channels, use the Left button to highlight the TV Channel. Press the centre Menu button to select the TV channel. Select Sub Channel until the desired sub-channel is selected.

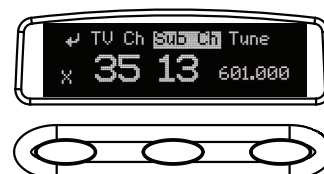

↳ *Remember, for a given channel / sub channel, the actual frequency will change depending on the TV Channel Mapping setting.*

The frequency is displayed with an asterisk (*) when the tune value does not fall within the pre-allocated sub channel.

See the [Frequency Tables](#) in this guide for a complete list of frequencies corresponding to the channel and sub channel selections.

Audio Input and Control

The A10-TX input accepts a wide range of audio input types, including lavalier microphones, balanced microphones, and balanced and unbalanced line level signals. 12 V and 48 V phantom power is available for balanced microphones. The Selection Menu offers options for input type, limiters, and low cut filter.

Lavalier Microphones

Unbalanced lavalier microphones wired in two-wire mode, are directly compatible with the A10-TX input. When connected, the A10-TX auto-detects the presence of a lav microphone.

A10-TX User Guide

Balanced Microphones with Phantom

Balanced microphones, including phantom powered shotgun microphones, can be connected to the A10-TX. 12 V and 48 V phantom power are available for microphones requiring it. For microphones that can properly operate on 12 V phantom, such as the Schoeps CMIT, select 12 V phantom to significantly increase battery runtime.

Line-Level Sources

Wireless systems are often used as “camera hop” systems. For most camera hop applications the output of a field mixer is connected to a wireless transmitter. The wireless receiver output is connected to the camera input. The line level input selection simplifies using the A10 System as a camera hop. Select Line in the Selection Menu to accept balanced or unbalanced line level inputs.

↳ *To connect balanced microphone or line level sources to the A10-TX, a cable wired as described in the specifications or the AC-BALXLR cable is required. This connects the shell of the LEMO connector to pin-1 of an XLR connector.*

Audio Level Control

Input levels are controlled from the Audio Gain option in the Selection Menu. The gain range available is source-dependent as follows:

- Lav setting: 0 dB to 40 dB, 1 dB increments
- Line setting: -10 to 16 dB, 1 dB increments
- Mic setting (with 20 dB pad): 16 to 40 dB, 1 dB increments
- Mic setting (with no pad): 36 to 60 dB

Set input levels so that the limiter is active only on the strongest peaks.

Antennas

The SMA antenna connector is used to mount the included 1/4-wave whip antenna. For specialty applications external, high-gain transmitting antennas can be attached to the SMA connector. Make certain to connect only passive antennas to the A10-TX.

For best operation and transmission power with the included 1/4-wave antenna keep it in the free field. If worn on a body keep the antenna away from direct contact with the wearer's body. When multiple wireless systems are in use keep transmitters separated by at least 1/2-wave distance of the transmitted frequency.

Recording

The A10-TX incorporates a data recorder that stores encoded digital waveform and timecode data in proprietary, data-compressed binary .mic files. Files recorded on the A10-TX are not sound files and require conversion using Audio Ltd's Mic2Wav application. (For more information, see [File Conversion .MIC to .WAV](#)). After conversion, a usable 48 kHz digital audio WAV file is made. Files recorded in the A10-TX are approximately 1/3 the size of WAV files generated from corresponding .mic files, saving valuable space on the microSD card. Files have a maximum duration of six hours. After six hours the file is automatically split into another recording. Resulting WAV files are sample accurate across file splits.

To begin recording on the A10-TX:

» Select *Menu > Record/TC > Record*.

Recording can also be initiated from the A10-TX Remote App. The default file name of the .mic file is the serial number of the A10 transmitter; however, the file name may be renamed via the A10-TX Remote app. For more information, see [Remote Control](#).

A10-TX User Guide

An indicator flashes in the display to show that the A10-TX is recording. This indicator is also shown on the A10-RX, in the TX data screen, accessed by pressing the Right button on the A10-RX receiver.

File Storage

Proprietary .mic files generated by the A10-TX are stored on FAT32-formatted microSD cards. The microSD card slot is located in the battery compartment and is accessed by removing the battery nearest the display.

If no microSD card is inserted in the unit, a ‘No card detected’ message is indicated.

New cards, or cards with material that can be overwritten, can be formatted in the A10-TX.

↳ *Formatting deletes all existing recordings present on the card.*

There is no provision to manage files from the A10-TX. File management, including file renaming and individual file deletion, is done when the microSD card is mounted to a computer via a card reader.

File Conversion .MIC to .WAV

The .mic files generated directly on the A10-TX are not usable until converted. Audio Ltd. provides a free Mic2Wav conversion utility, available for download from the Audio Ltd. website: www.audioltd.com. This utility—available for Mac or Windows operating systems—converts .mic files to usable Broadcast WAV files.

Timecode and Time-of-Day Clocks

The A10-TX includes high-precision internal clocks to maintain time-of-day/date and SMPTE timecode. These clock runs continuously when AA batteries are in the unit and draw negligible current (less than 1 uA). The A10-TX design incorporates a supercapacitor to power the time-of-day clock for several days in the absence of batteries. The supercapacitor reaches full charge when batteries have been in the unit for five minutes.

Time-of-Day Clock

The time and date clock holds time and date for files recorded on the A10-TX, and can be used for the Time of Day timecode value.

To set time and date:

1. Enter the Selection Menu option real time clock. (*Menu > System > Set Time/Date*)
2. Use the centre Menu button to move between year, month, day, hours, and minutes. Use the Left and Right buttons to change the values.
3. Press the centre Menu button to select the Return arrow and view current values. Press again to exit.

External LTC Jamming

External LTC timecode can be applied to the A10-TX to synchronize its internal timecode clock. Synchronization of timecode clocks is called “jam syncing”. To jam the A10-TX timecode clock, navigate to *Menu > Record/TC > Timecode* in the Selection menu. Connect an LTC timecode source to the 3-pin LEMO™ input connector using either the AC-TCLEMO or AC-TCBNC-IN cables. The A10-TX will jam its timecode clock from the incoming timecode signal.

↳ *Whilst in the Timecode menu, RF transmission and recording are deactivated on the A10-TX.*

The timecode clock remains accurate when the transmitter is powered or in standby mode. When the unit is powered down accurate timecode is held for six hours. After six hours the timecode clock is reset to its default value.

Timecode Output

The A10-TX 3-pin LEMO connector also functions as a timecode output connection. In the Selection menu navigate to *Menu > Record/TC > Timecode*. While in this screen timecode can be sent out of the A10-TX using the AC-TCLEMO or AC-TCBNC-OUT cables.

Upon exiting the timecode menu the 3-pin LEMO reverts back to the selected lav, mic, or line input. RF transmission is reactivated and recording is available.

Remote Control

The A10-TX can be remotely controlled from an Android or iOS device running the A10-TX Remote app. The app is available as a free download from the Google Play store and iOS App store, respectively.

With the A10-TX Remote app, you can:

- | | |
|--|--|
| <ul style="list-style-type: none"> 1 - Change the transmitter's name; it is set to the transmitter's serial number by default. 2 - View timecode and frame rate 3 - Monitor Sleep status, Battery status, Bluetooth signal strength and Record status 4 - Turn Sleep mode On/Off | <ul style="list-style-type: none"> 5 - Start/Stop recording at the transmitter 6 - Adjust Gain 7 - Set the low-cut filter 8 - Adjust RF Power 9 - Change TV Ch, Sub Ch and Frequency |
|--|--|

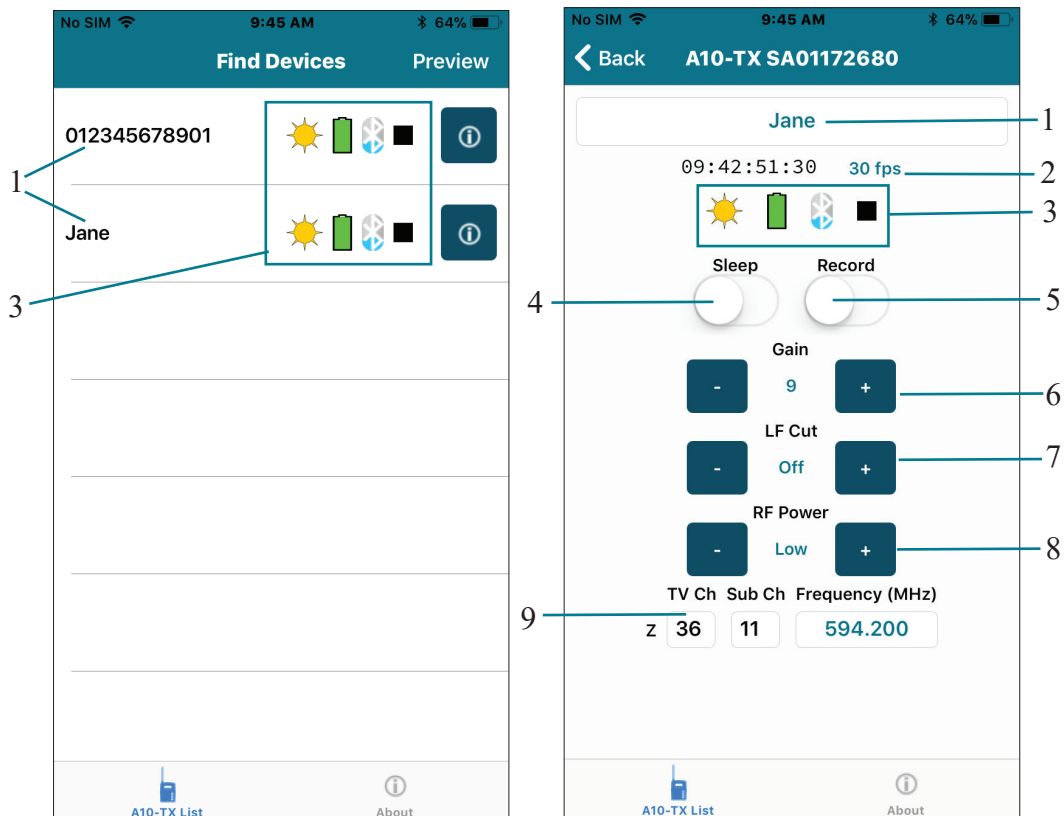

Touch the unit name (left screen) to access more information (image on right) about the transmitter. Touch the Circle-I icon to send identification signal to the transmitter.

↳ *The Bluetooth operational range is very short. Maintain close proximity to the transmitter for reliable connection.*

Firmware Updates

Audio Ltd. issues new firmware for the A10-TX transmitter to change and introduce new features to the unit. Make certain to register your Audio Ltd. product at the Audio Ltd. website to receive firmware update notifications.

To update firmware:

1. Download the new firmware update file from the Audio Ltd. website and copy the file onto an approved microSD card that has been formatted in the A10-TX.
2. Insert the microSD card in the unit.
3. Insert fresh AA batteries in the unit.
4. Enter the System menu and choose Update. The unit will indicate the revision of firmware to update.
5. Confirm that you want to update. This starts the update process.
6. Do not power down the unit until instructed to do so.
7. Verify the revision of firmware on the unit.

A10-TX User Guide

Specifications

A10 Digital Wireless System Frequency Range	470–694 MHz														
Transmitter Switching Bandwidth	UK and International Models: A10-TX-A (470–548 MHz) A10-TX-B (518–608 MHz) A10-TX-C (594–694 MHz) Transmitters are tunable in 25 kHz steps.	U.S. Only Models: <i>See the A10-TX-US User Guide for more information on these models.</i> A10-TX-AU (470–548 MHz) A10-TX-BU (518–608 MHz)													
Modulation Mode	Audio Ltd. proprietary digital RF modulation														
Digital Audio Codec	Audio Ltd. proprietary, high-performance digital encoding algorithm														
Audio Frequency Response	20 Hz–20 kHz														
RF Output Power	Low: 10 mW, Med: 20 mW, High: 50 mW, selectable														
Audio Gain Control	Lav setting: 0 dB to +40 dB, 1 dB increments Line setting: -10 to 16 dB, 1 dB increments Mic setting (w/ 20 dB pad): 16 to 40 dB, 1 dB increments Mic setting (w/ no pad): 36 to 60 dB, 1 dB increments														
Input Gain	<table border="1" style="width: 100%; border-collapse: collapse;"> <thead> <tr> <th style="width: 40%;">Input Type</th> <th style="width: 20%;">Input Impedance (ohms)</th> <th style="width: 40%;">Input Clipping Level (minimum gain)</th> </tr> </thead> <tbody> <tr> <td>Lav</td> <td>6.8k</td> <td>+6 dBu</td> </tr> <tr> <td>Bal Mic - plus P48 and P12</td> <td>2.5k</td> <td>+10 dBu (20 dB pad)</td> </tr> <tr> <td>Bal Line</td> <td>3k</td> <td>+24 dBu</td> </tr> </tbody> </table>			Input Type	Input Impedance (ohms)	Input Clipping Level (minimum gain)	Lav	6.8k	+6 dBu	Bal Mic - plus P48 and P12	2.5k	+10 dBu (20 dB pad)	Bal Line	3k	+24 dBu
Input Type	Input Impedance (ohms)	Input Clipping Level (minimum gain)													
Lav	6.8k	+6 dBu													
Bal Mic - plus P48 and P12	2.5k	+10 dBu (20 dB pad)													
Bal Line	3k	+24 dBu													
Low Frequency Cut	Off, 40 Hz, 60 Hz, 80 Hz, 100 Hz, 200 Hz, user selectable														
Input Limiter	Analogue, (pre-A/D converter)														
Input Type	Microphone or line level, balanced or unbalanced														
Bias and Phantom Power	5 V Bias, 12 V or 48 V phantom power														
Menu and Controls	OLED menu display, 3 button navigation														
Recording File Format	Audio Ltd. proprietary .mic data file, requires conversion to WAV file														
microSD Card	microSD, microSDHC, microSDXC														
Timecode Clock	0.2 ppm accuracy, holds accurate clock for 6 hours without power														
Privacy	User settable 4-digit PIN, Audio Ltd. proprietary														
Powering	2 x 1.5V LR6 AA size, lithium, NiMH, or alkaline														
Operating Temperature Range	-10 °C to +55 °C														
Weight and Dimensions	104 g, 83 x 64 x 18 mm														

Input Connector Wiring Diagram

The A10-TX LEMO input connector accepts numerous input types. Select the input type in the Selection Menu before connecting an audio source.

Input Type	LEMO Connection			
	pin-1	pin-2	pin-3	shell
Two-Wire Lavalier Microphone	shield	open	audio/bias	shield or open
Three-Wire Lavalier Microphone	not compatible			
Balanced Microphone	XLR pin-3	XLR pin-2	XLR pin-1	XLR pin-1, shell optional
Balanced Line-Level	XLR pin-3	XLR pin-2	XLR pin-1	XLR pin-1, shell optional
Unbalanced Microphone	earth	signal	earth	earth
Unbalanced Line-Level	earth	signal	earth	earth
Timecode	earth	LTC out of A10-TX	LTC into A10-TX	earth or open

↪ Phantom power can be activated only when the shell of the LEMO-3 is connected to pin-3 of the LEMO-3 connector.

Battery Runtime Chart

There are many factors that will alter run times, including the mic in use.

This section's chart shows approximate battery runtime in minutes based on the listed operation.

Operation	Battery Type		
	NiMH (2450 mAh)	Alkaline	Lithium (Energizer Ultimate)
recording only	18 hr 53 min	14 hr 26 min	33 hr 5 min
10 mW (RF Power Low)	8 hr 12 min	4 hr 7 min	12 hr 18 min
20 mW (RF Power Med)	7 hr 29 min	3 hr 56 min	11 hr 31 min
50 mW (RF Power High)	4 hr 33 min	2 hr 21 min	7 hr 57 min
recording only, 48 V	9 hr 47 min	6 hr 2 min	17 hr 44 min
50 mW, 48 V	3 hr 29 min	1 hr 33 min	6 hr 20 min

↳ *The 48 V tests were run with a Schoeps CMIT Mini. Other settings used for tests to compile the chart are: Low Cut Off, Limiter On, 40 dB gain (for 48 V)/30 dB gain (for Lav), freshly formatted 8G card (16 hr record time), Bluetooth On, Blue LED On, and Brightness set to 5.*

Certifications

Industry Canada Conformity

EN: This device complies with Industry Canada RSS-210. Operation is subject to the following two conditions: (1) this device may not cause interference, and (2) this device must accept any interference, including interference that may cause undesired operation of the device.

FR :Le présent appareil est conforme aux CNR d'Industrie Canada applicables aux appareils radio RSS-210. L'exploitation est autorisée aux deux conditions suivantes: (1) l'appareil ne doit pas produire de brouillage, et (2) l'utilisateur de l'appareil doit accepter tout brouillage radioélectrique subi, même si le brouillage est susceptible d'en compromettre le fonctionnement.

FCC Conformity

The A10-TX transmitter complies with the following requirements:

FCC (Federal Communications Commission) Part 74

Operation is subject to the following two conditions:

- (1) This device may not cause harmful interference, and
- (2) This device must accept any interference received, including interference that may cause undesired operations.

Changes or modification not expressly approved.

A10-TX frequency ranges supplied for use in USA.

A10-TX transmitters available for sale in the U. S. can tune over a switching bandwidth of up to 100 MHz. The frequency ranges are listed below:

- 470.1–547.9 MHz
- 518.1–607.9 MHz

↳ *Frequency range 608–614 MHz is forbidden for use in US.*

↳ **Warning! Any modifications or changes made to this device, unless explicitly approved by Audio Ltd. may invalidate the authorisation of this device. Operation of an unauthorised**

A10-TX User Guide

device is prohibited under Section 302 of the Communications act of 1934, as amended, and Subpart 1 of Part 2 of Chapter 47 of the Code of Federal Regulations.

Minimize RF Exposure

To avoid the possibility of exceeding the FCC RF exposure limits, it is recommended that the transmitter or attached microphone be kept at a minimum distance of 13 mm (0.5 inch) away from the head or body during normal operation.

Frequency Tables

The A10-TX offers preselected frequencies based on channels and sub channels. Three sets of frequencies are available based on either 6, 7, or 8 MHz channel bandwidth. Select the channel bandwidth based on the geographic region where the unit is operating.

X Frequencies (6 MHz Per TV Channel)

The chart below shows all frequencies available for the A10 wireless system. Not all channels are available on all transmitters.

		Sub Channel														
		1	2	3	4	5	6	7	8	9	10	11	12	13	14	15
Channel	14	470.2	470.6	471	471.4	471.8	472.2	472.6	473	473.4	473.8	474.2	474.6	475	475.4	475.8
	15	476.2	476.6	477	477.4	477.8	478.2	478.6	479	479.4	479.8	480.2	480.6	481	481.4	481.8
	16	482.2	482.6	483	483.4	483.8	484.2	484.6	485	485.4	485.8	486.2	486.6	487	487.4	487.8
	17	488.2	488.6	489	489.4	489.8	490.2	490.6	491	491.4	491.8	492.2	492.6	493	493.4	493.8
	18	494.2	494.6	495	495.4	495.8	496.2	496.6	497	497.4	497.8	498.2	498.6	499	499.4	499.8
	19	500.2	500.6	501	501.4	501.8	502.2	502.6	503	503.4	503.8	504.2	504.6	505	505.4	505.8
	20	506.2	506.6	507	507.4	507.8	508.2	508.6	509	509.4	509.8	510.2	510.6	511	511.4	511.8
	21	512.2	512.6	513	513.4	513.8	514.2	514.6	515	515.4	515.8	516.2	516.6	517	517.4	517.8
	22	518.2	518.6	519	519.4	519.8	520.2	520.6	521	521.4	521.8	522.2	522.6	523	523.4	523.8
	23	524.2	524.6	525	525.4	525.8	526.2	526.6	527	527.4	527.8	528.2	528.6	529	529.4	529.8
	24	530.2	530.6	531	531.4	531.8	532.2	532.6	533	533.4	533.8	534.2	534.6	535	535.4	535.8
	25	536.2	536.6	537	537.4	537.8	538.2	538.6	539	539.4	539.8	540.2	540.6	541	541.4	541.8
	26	542.2	542.6	543	543.4	543.8	544.2	544.6	545	545.4	545.8	546.2	546.6	547	547.4	547.8
	27	548.2	548.6	549	549.4	549.8	550.2	550.6	551	551.4	551.8	552.2	552.6	553	553.4	553.8
	28	554.2	554.6	555	555.4	555.8	556.2	556.6	557	557.4	557.8	558.2	558.6	559	559.4	559.8
	29	560.2	560.6	561	561.4	561.8	562.2	562.6	563	563.4	563.8	564.2	564.6	565	565.4	565.8
	30	566.2	566.6	567	567.4	567.8	568.2	568.6	569	569.4	569.8	570.2	570.6	571	571.4	571.8
	31	572.2	572.6	573	573.4	573.8	574.2	574.6	575	575.4	575.8	576.2	576.6	577	577.4	577.8
	32	578.2	578.6	579	579.4	579.8	580.2	580.6	581	581.4	581.8	582.2	582.6	583	583.4	583.8
	33	584.2	584.6	585	585.4	585.8	586.2	586.6	587	587.4	587.8	588.2	588.6	589	589.4	589.8
	34	590.2	590.6	591	591.4	591.8	592.2	592.6	593	593.4	593.8	594.2	594.6	595	595.4	595.8
	35	596.2	596.6	597	597.4	597.8	598.2	598.6	599	599.4	599.8	600.2	600.6	601	601.4	601.8
	36	602.2	602.6	603	603.4	603.8	604.2	604.6	605	605.4	605.8	606.2	606.6	607	607.4	607.8
	37	608.2	608.6	609	609.4	609.8	610.2	610.6	611	611.4	611.8	612.2	612.6	613	613.4	613.8
	38	614.2	614.6	615	615.4	615.8	616.2	616.6	617	617.4	617.8	618.2	618.6	619	619.4	619.8
	39	620.2	620.6	621	621.4	621.8	622.2	622.6	623	623.4	623.8	624.2	624.6	625	625.4	625.8
	40	626.2	626.6	627	627.4	627.8	628.2	628.6	629	629.4	629.8	630.2	630.6	631	631.4	631.8
	41	632.2	632.6	633	633.4	633.8	634.2	634.6	635	635.4	635.8	636.2	636.6	637	637.4	637.8
	42	638.2	638.6	639	639.4	639.8	640.2	640.6	641	641.4	641.8	642.2	642.6	643	643.4	643.8
	43	644.2	644.6	645	645.4	645.8	646.2	646.6	647	647.4	647.8	648.2	648.6	649	649.4	649.8
	44	650.2	650.6	651	651.4	651.8	652.2	652.6	653	653.4	653.8	654.2	654.6	655	655.4	655.8
	45	656.2	656.6	657	657.4	657.8	658.2	658.6	659	659.4	659.8	660.2	660.6	661	661.4	661.8
46	662.2	662.6	663	663.4	663.8	664.2	664.6	665	665.4	665.8	666.2	666.6	667	667.4	667.8	
47	668.2	668.6	669	669.4	669.8	670.2	670.6	671	671.4	671.8	672.2	672.6	673	673.4	673.8	
48	674.2	674.6	675	675.4	675.8	676.2	676.6	677	677.4	677.8	678.2	678.6	679	679.4	679.8	
49	680.2	680.6	681	681.4	681.8	682.2	682.6	683	683.4	683.8	684.2	684.6	685	685.4	685.8	
50	686.2	686.6	687	687.4	687.8	688.2	688.6	689	689.4	689.8	690.2	690.6	691	691.4	691.8	
51	692.2	692.6	693	693.4	693.8	694.2	694.6	695	695.4	695.8	696.2	696.6	697	697.4	697.8	

A10-TX User Guide

Y Frequencies (7 MHz Per TV Channel)

		Sub Channels																
		1	2	3	4	5	6	7	8	9	10	11	12	13	14	15	16	17
Channels	22	485.3	485.7	486.1	486.5	486.9	487.3	487.7	488.1	488.5	488.9	489.3	489.7	490.1	490.5	490.9	491.3	491.7
	23	492.3	492.7	493.1	493.5	493.9	494.3	494.7	495.1	495.5	495.9	496.3	496.7	497.1	497.5	497.9	498.3	498.7
	24	499.3	499.7	500.1	500.5	500.9	501.3	501.7	502.1	502.5	502.9	503.3	503.7	504.1	504.5	504.9	505.3	505.7
	25	506.3	506.7	507.1	507.5	507.9	508.3	508.7	509.1	509.5	509.9	510.3	510.7	511.1	511.5	511.9	512.3	512.7
	26	513.3	513.7	514.1	514.5	514.9	515.3	515.7	516.1	516.5	516.9	517.3	517.7	518.1	518.5	518.9	519.3	519.7
	27	520.3	520.7	521.1	521.5	521.9	522.3	522.7	523.1	523.5	523.9	524.3	524.7	525.1	525.5	525.9	526.3	526.7
	28	527.3	527.7	528.1	528.5	528.9	529.3	529.7	530.1	530.5	530.9	531.3	531.7	532.1	532.5	532.9	533.3	533.7
	29	534.3	534.7	535.1	535.5	535.9	536.3	536.7	537.1	537.5	537.9	538.3	538.7	539.1	539.5	539.9	540.3	540.7
	30	541.3	541.7	542.1	542.5	542.9	543.3	543.7	544.1	544.5	544.9	545.3	545.7	546.1	546.5	546.9	547.3	547.7
	31	548.3	548.7	549.1	549.5	549.9	550.3	550.7	551.1	551.5	551.9	552.3	552.7	553.1	553.5	553.9	554.3	554.7
	32	555.3	555.7	556.1	556.5	556.9	557.3	557.7	558.1	558.5	558.9	559.3	559.7	560.1	560.5	560.9	561.3	561.7
	33	562.3	562.7	563.1	563.5	563.9	564.3	564.7	565.1	565.5	565.9	566.3	566.7	567.1	567.5	567.9	568.3	568.7
	34	569.3	569.7	570.1	570.5	570.9	571.3	571.7	572.1	572.5	572.9	573.3	573.7	574.1	574.5	574.9	575.3	575.7
	35	576.3	576.7	577.1	577.5	577.9	578.3	578.7	579.1	579.5	579.9	580.3	580.7	581.1	581.5	581.9	582.3	582.7
	36	583.3	583.7	584.1	584.5	584.9	585.3	585.7	586.1	586.5	586.9	587.3	587.7	588.1	588.5	588.9	589.3	589.7
	37	590.3	590.7	591.1	591.5	591.9	592.3	592.7	593.1	593.5	593.9	594.3	594.7	595.1	595.5	595.9	596.3	596.7
	38	597.3	597.7	598.1	598.5	598.9	599.3	599.7	600.1	600.5	600.9	601.3	601.7	602.1	602.5	602.9	603.3	603.7
	39	604.3	604.7	605.1	605.5	605.9	606.3	606.7	607.1	607.5	607.9	608.3	608.7	609.1	609.5	609.9	610.3	610.7
	40	611.3	611.7	612.1	612.5	612.9	613.3	613.7	614.1	614.5	614.9	615.3	615.7	616.1	616.5	616.9	617.3	617.7
	41	618.3	618.7	619.1	619.5	619.9	620.3	620.7	621.1	621.5	621.9	622.3	622.7	623.1	623.5	623.9	624.3	624.7
	42	625.3	625.7	626.1	626.5	626.9	627.3	627.7	628.1	628.5	628.9	629.3	629.7	630.1	630.5	630.9	631.3	631.7
	43	632.3	632.7	633.1	633.5	633.9	634.3	634.7	635.1	635.5	635.9	636.3	636.7	637.1	637.5	637.9	638.3	638.7
	44	639.3	639.7	640.1	640.5	640.9	641.3	641.7	642.1	642.5	642.9	643.3	643.7	644.1	644.5	644.9	645.3	645.7
	45	646.3	646.7	647.1	647.5	647.9	648.3	648.7	649.1	649.5	649.9	650.3	650.7	651.1	651.5	651.9	652.3	652.7
	46	653.3	653.7	654.1	654.5	654.9	655.3	655.7	656.1	656.5	656.9	657.3	657.7	658.1	658.5	658.9	659.3	659.7
	47	660.3	660.7	661.1	661.5	661.9	662.3	662.7	663.1	663.5	663.9	664.3	664.7	665.1	665.5	665.9	666.3	666.7
	48	667.3	667.7	668.1	668.5	668.9	669.3	669.7	670.1	670.5	670.9	671.3	671.7	672.1	672.5	672.9	673.3	673.7
	49	674.3	674.7	675.1	675.5	675.9	676.3	676.7	677.1	677.5	677.9	678.3	678.7	679.1	679.5	679.9	680.3	680.7
	50	681.3	681.7	682.1	682.5	682.9	683.3	683.7	684.1	684.5	684.9	685.3	685.7	686.1	686.5	686.9	687.3	687.7
	51	688.3	688.7	689.1	689.5	689.9	690.3	690.7	691.1	691.5	691.9	692.3	692.7	693.1	693.5	693.9	694.3	694.7

A10-TX User Guide

Z Frequencies (8 MHz Per TV Channel)

		Sub Channels																			
		1	2	3	4	5	6	7	8	9	10	11	12	13	14	15	16	17	18	19	20
Channels	21	470.2	470.6	471.0	471.4	471.8	472.2	472.6	473.0	473.4	473.8	474.2	474.6	475.0	475.4	475.8	476.2	476.6	477.0	477.4	477.8
	22	478.2	478.6	479.0	479.4	479.8	480.2	480.6	481.0	481.4	481.8	482.2	482.6	483.0	483.4	483.8	484.2	484.6	485.0	485.4	485.8
	23	486.2	486.6	487.0	487.4	487.8	488.2	488.6	489.0	489.4	489.8	490.2	490.6	491.0	491.4	491.8	492.2	492.6	493.0	493.4	493.8
	24	494.2	494.6	495.0	495.4	495.8	496.2	496.6	497.0	497.4	497.8	498.2	498.6	499.0	499.4	499.8	500.2	500.6	501.0	501.4	501.8
	25	502.2	502.6	503.0	503.4	503.8	504.2	504.6	505.0	505.4	505.8	506.2	506.6	507.0	507.4	507.8	508.2	508.6	509.0	509.4	509.8
	26	510.2	510.6	511.0	511.4	511.8	512.2	512.6	513.0	513.4	513.8	514.2	514.6	515.0	515.4	515.8	516.2	516.6	517.0	517.4	517.8
	27	518.2	518.6	519.0	519.4	519.8	520.2	520.6	521.0	521.4	521.8	522.2	522.6	523.0	523.4	523.8	524.2	524.6	525.0	525.4	525.8
	28	526.2	526.6	527.0	527.4	527.8	528.2	528.6	529.0	529.4	529.8	530.2	530.6	531.0	531.4	531.8	532.2	532.6	533.0	533.4	533.8
	29	534.2	534.6	535.0	535.4	535.8	536.2	536.6	537.0	537.4	537.8	538.2	538.6	539.0	539.4	539.8	540.2	540.6	541.0	541.4	541.8
	30	542.2	542.6	543.0	543.4	543.8	544.2	544.6	545.0	545.4	545.8	546.2	546.6	547.0	547.4	547.8	548.2	548.6	549.0	549.4	549.8
	31	550.2	550.6	551.0	551.4	551.8	552.2	552.6	553.0	553.4	553.8	554.2	554.6	555.0	555.4	555.8	556.2	556.6	557.0	557.4	557.8
	32	558.2	558.6	559.0	559.4	559.8	560.2	560.6	561.0	561.4	561.8	562.2	562.6	563.0	563.4	563.8	564.2	564.6	565.0	565.4	565.8
	33	566.2	566.6	567.0	567.4	567.8	568.2	568.6	569.0	569.4	569.8	570.2	570.6	571.0	571.4	571.8	572.2	572.6	573.0	573.4	573.8
	34	574.2	574.6	575.0	575.4	575.8	576.2	576.6	577.0	577.4	577.8	578.2	578.6	579.0	579.4	579.8	580.2	580.6	581.0	581.4	581.8
	35	582.2	582.6	583.0	583.4	583.8	584.2	584.6	585.0	585.4	585.8	586.2	586.6	587.0	587.4	587.8	588.2	588.6	589.0	589.4	589.8
	36	590.2	590.6	591.0	591.4	591.8	592.2	592.6	593.0	593.4	593.8	594.2	594.6	595.0	595.4	595.8	596.2	596.6	597.0	597.4	597.8
	37	598.2	598.6	599.0	599.4	599.8	600.2	600.6	601.0	601.4	601.8	602.2	602.6	603.0	603.4	603.8	604.2	604.6	605.0	605.4	605.8
	38	606.2	606.6	607.0	607.4	607.8	608.2	608.6	609.0	609.4	609.8	610.2	610.6	611.0	611.4	611.8	612.2	612.6	613.0	613.4	613.8
	39	614.2	614.6	615.0	615.4	615.8	616.2	616.6	617.0	617.4	617.8	618.2	618.6	619.0	619.4	619.8	620.2	620.6	621.0	621.4	621.8
	40	622.2	622.6	623.0	623.4	623.8	624.2	624.6	625.0	625.4	625.8	626.2	626.6	627.0	627.4	627.8	628.2	628.6	629.0	629.4	629.8
	41	630.2	630.6	631.0	631.4	631.8	632.2	632.6	633.0	633.4	633.8	634.2	634.6	635.0	635.4	635.8	636.2	636.6	637.0	637.4	637.8
	42	638.2	638.6	639.0	639.4	639.8	640.2	640.6	641.0	641.4	641.8	642.2	642.6	643.0	643.4	643.8	644.2	644.6	645.0	645.4	645.8
	43	646.2	646.6	647.0	647.4	647.8	648.2	648.6	649.0	649.4	649.8	650.2	650.6	651.0	651.4	651.8	652.2	652.6	653.0	653.4	653.8
	44	654.2	654.6	655.0	655.4	655.8	656.2	656.6	657.0	657.4	657.8	658.2	658.6	659.0	659.4	659.8	660.2	660.6	661.0	661.4	661.8
	45	662.2	662.6	663.0	663.4	663.8	664.2	664.6	665.0	665.4	665.8	666.2	666.6	667.0	667.4	667.8	668.2	668.6	669.0	669.4	669.8
	46	670.2	670.6	671.0	671.4	671.8	672.2	672.6	673.0	673.4	673.8	674.2	674.6	675.0	675.4	675.8	676.2	676.6	677.0	677.4	677.8
	47	678.2	678.6	679.0	679.4	679.8	680.2	680.6	681.0	681.4	681.8	682.2	682.6	683.0	683.4	683.8	684.2	684.6	685.0	685.4	685.8
	48	686.2	686.6	687.0	687.4	687.8	688.2	688.6	689.0	689.4	689.8	690.2	690.6	691.0	691.4	691.8	692.2	692.6	693.0	693.4	693.8

Channel Assignments by Region

Region	AL Frequency Region
North America, South Korea, Taiwan, Philippines	X
UK and Western Europe , Greenland, Asia, Africa	Z
Australia and New Zealand	Y
Japan	X
Taiwan	X
China	X

For further information, contact Audio Ltd or your local distributor
 Copyright © 2017 Audio Ltd. All rights reserved. | www.audioltd.com
 7 Century Court, Tolpits Lane, Watford WD18 9RS, UK | info@audioltd.com