

SOUND DEVICES



442

Field Mixer

User Guide and Technical Information

for 442 and 442 Nordic Field Mixers

Sound Devices, LLC
300 Wengel Drive
Reedsburg, WI 53959 USA
Voice +1 (608) 524-0625
Fax +1 (608) 524-0655
www.sounddevices.com

©2003–2008 Sound Devices, LLC

Table of Contents

Quick Start Guide	3	Ballistics Lock	11
Powering	3	Headphone Peak LED	12
Input Channel Setup	3	Headphone Monitoring	12
Output Connection	3	Headphone Source Selection	12
Headphone Monitoring	3	Headphone Gain	12
Metering	3	Return A and B	12
Limiting	3	Powering	13
Front Panel Descriptions	4	Internal Powering	13
Input Panel Descriptions	5	External Powering	13
Output Panel Descriptions	6	Power Metering	13
Input Channels	7	Power Consumption	13
Mic/Line Level Selection	7	Tone Oscillator / Slate Microphone	14
Gain	7	Tone Oscillator	14
Faders	7	Slate Microphone	14
Microphone Powering	7	Accessing the Setup Menu	15
High-Pass Filters	8	Enter the Setup Menu	15
Pan Controls	8	User Default	15
Channel Limiters	8	442 Nordic Information	16
Peak LEDs	9	Setup Menus	16
Polarity Reversal - Channel 2	9	Setup Menu Firmware v 5	17
Stereo Link ON - Channels 1 and 2	9	Setup Menu Firmware v 3 & 4	18
Stereo Link MS - Channels 1 and 2	9	Setup Menu Firmware v 2, (442 only)	19
PFL (Channel Solo Monitoring)	9	Specifications	20
Master Gain Control	9	Inputs	20
Master Outputs - XLR and Hirose Multi-Pin	10	Outputs	21
Secondary Balanced Outputs	10	Block Diagram - Inputs and Outputs	23
Tape Outputs (Mix Output)	10	Block Diagram - Monitoring	24
Mono Mic Output	10	Accessories	25
Output Limiter	10	CE Declaration of Conformity	26
LINK vs ON	10	Warranty and Technical Support	27
Mix Input (linking mixers)	11	FCC Statement	27
Metering	11		
Meter Ballistics	11		

Welcome

Developed with insight from the industry's top audio engineers, the 442 Field Mixer encompasses the audio performance, feature set, and mechanical construction demanded by those who rely on audio gear for their livelihood. The 442 contains four high-performance microphone preamplifiers, multiple outputs, and flexible monitoring. Its inputs and outputs, including direct outputs on each channel, make the 442 at home in small "run-and-gun" applications as well as large, multiple input productions.

The 442 incorporates a complete feature-set into a compact, functional design. With no hidden controls, the 442's parameters are accessible from the three main surfaces. The highly efficient circuitry allows the mixer to be powered by either four internal AA batteries or external 5-18 VDC.

The 442, like all Sound Devices professional audio products, is designed to withstand the physical and environmental extremes inherent to field production. Its compact construction strikes the perfect balance between performance, accessible controls, and durability.

Quick Start Guide

For those familiar with field mixers or mixing consoles, this "Quick Start Guide" highlights basic functionality to begin operating the 442.

Powering

1. For internal powering, insert four AA batteries with the positive (+) side first into the battery compartment.
For external powering, connect the external DC power (5–18 VDC) to the 442's DC connector.
2. Slide the power switch in the direction of the intended power source (INT or EXT).
3. Press the battery check button to view voltage levels.

Input Channel Setup

1. Connect a signal source (microphone or line level signal) to a channel's XLR input connector.
2. Select the input type to MIC or LINE level.
3. Engage Phantom or T-power, if required by the input source.
4. Set the Channel Fader to the 0 (unity) position.
5. Adjust the Channel Pan to the appropriate position.
6. Adjust the High-Pass filter as needed.
7. Place the Master Gain control to the 0 (unity) position.
8. Adjust the Channel Gain/trim control to the required level.
9. Verify that signal is present on the Output Meter.

Output Connection

1. Connect the outputs of the 442 to the inputs of the receiving device.
2. Select the output type - MIC, -10, or LINE level.
3. Verify that the receiving device is getting signal.

Headphone Monitoring

1. Connect headphones to the either one of the headphone connectors located on the Output Panel.
2. Turn the Monitor Selection Switch the ST position to listen to stereo mixer program.
3. Monitor the stereo mix in the headphones.

Metering

1. View the master output level on the LED Output Meter.
2. Toggle between VU, PPM (Peak), or combined VU/PPM metering with the PK/VU button.
3. Adjust the meter brightness among its intensities with the LED Brightness button.

Limiting

1. Activate the input and output limiters by engaging the front panel switch - either stereo linked (LINK) or dual mono (ON).
2. Note the limiting activity on the limiter LEDs and the output level.
3. Adjust the output limiter threshold and input limiter availability in the Setup Menu (see Appendix).

Front Panel Descriptions

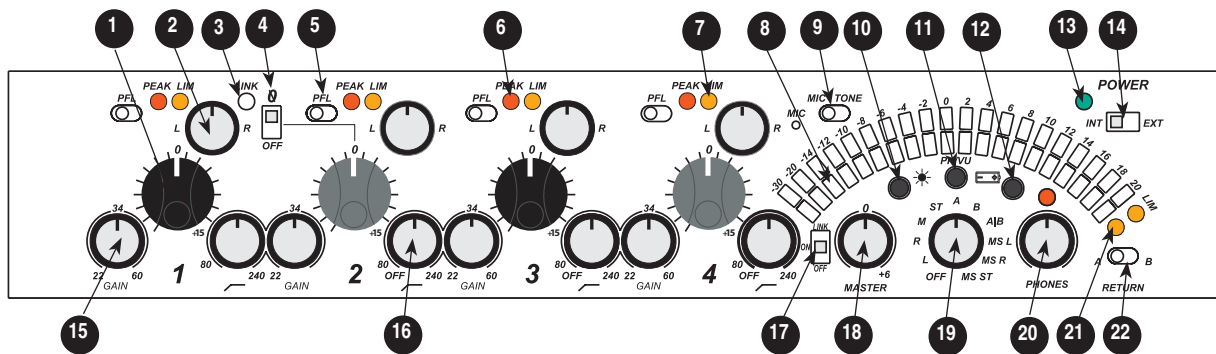

- 1) **Channel Fader**
Primary control for adjusting the input level of each channel during operation. Ranges from Off to +15 dB. Nominal setting is in the middle (0 dB).
- 2) **Channel Pan**
Controls the Left/Right balance of the input signal to the outputs. Signal is 3 dB greater when panned hard left and right.
- 3) **LINK LED**
Indicates that channels 1 and 2 are linked as a stereo pair, set via the Link Switch on the input panel.
- 4) **Channel 2 Polarity Reverse**
Reverses the polarity of input channel 2.
- 5) **PFL (Solo)**
Pre-fade Listen. Sends the selected channel's post-gain/pre-fade signal to the headphone monitor for troubleshooting and gain staging. Does not affect master output signal.
- 6) **Peak LED**
Indicates that the input signal is 3 dB from clipping. If the LED illuminates, gain is set too high.
- 7) **Input Limiter LED**
Illuminates orange when the Input Limiter is active, LED intensity signifies amount of limiting. If significant limiting occurs, reduce the level of the Gain Trim.
- 8) **Output Meter**
40 segment output meter. For Peak setting, the markings indicate output level (at line-level) in dBu. For VU setting, markings indicate Volume Units. See Appendix A for 442N scale.
- 9) **Slate Mic / Tone Oscillator**
Activates the slate microphone in the left position (momentary) and activates the tone oscillator in the right position (latched).
- 10) **LED Brightness Button**
Toggles between the four LED brightness settings.
- 11) **PK/VU Button**
Toggles between the available output meter ballistics—VU, PPM (Peak), combined VU/PPM, or VU-PPM Hold. See Metering Hold down the PK/VU button while powering on the mixer to access the Setup Menu.
- 12) **Battery Check Button**
Views the battery level on the output meter. Left (top) meter indicates internal battery level, right (bottom) meter indicates external battery level. See Powering.
- 13) **Power LED**
Illuminates when unit is powered. Flashes when power supply is low. With external DC supply the LED flashes at select voltage. See Powering.

-
- 14) **Power Switch**
Three-position switch, selects between internal battery power or external DC sources, middle position is Off.
- 15) **Gain (Trim)**
Coarse input gain control. Sets the initial input sensitivity level so that the Channel Fader can be used for fine gain adjustments. Range is from +22 dB to +60 dB.
- 16) **High-Pass Filter**
Adjusts corner (-3 dB) frequency of high-pass filter. Full counter-clockwise position (de-tented) deactivates the High-Pass Filter. Range is 80-240 Hz, 12dB/oct to 6 dB/oct.
- 17) **Limiter Switch**
Activates both Input and Output Limiters. Input Limiters can be defeated in the Setup Menu. When ON is selected, the Output Limiters act independently on each Left and Right Outputs. When LINK is selected, the Output Limiters are linked and limiting is applied evenly across the Stereo Outputs.
- 18) **Master Gain**
Controls the overall signal level of the Left and Right Outputs.
- 19) **Monitor Selection Switch**
Selects the signal source in headphone monitor. Options include: Off; Left Output bus; Right Output bus; Mono (summed left and right); STereo master; Return A; Return B; Return A in the left / Return B in the right headphone monitor; MS-Left; MS Right; MS-stereo.
- 20) **Headphone Gain**
Adjusts the overall headphone gain.
- 21) **Output Limiter LEDs**
Illuminates orange when the Output Limiter is active, LED intensity signifies amount of limiting. If significant Output Limiting occurs, reduce the levels of the Channel and Master faders accordingly.
- 22) **Return Monitor Toggle Switch**
Sends the return audio signals to the headphone monitor. Left position latches and right position is momentary. Return routing relative to switch position can be modified in the Setup Menu. Factory default is RTN A on the left, middle is Off, and RTN B on the right.

Input Panel Descriptions

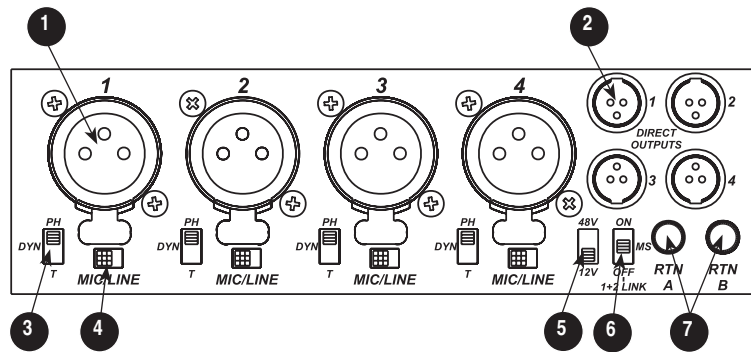

- 1) **XLR Inputs**
Transformer-balanced channel inputs. Pin-1 = ground; pin-2 = 'hot' (+); pin-3 = 'cold' (-). Unbalance by grounding pin-3 to pin-1 of the XLR connector.
- 2) **TA3M-type Channel Direct Outputs**
Balanced direct outputs. Signal is pre-fader (post-trim, input limiter, and high-pass filter). Output level is selected in the Setup Menu between Mic and Line-levels. Pin-1 = Ground; pin-2 = 'Hot'(+); pin-3 = 'Cold' (-). Unbalance by floating pin-3.
- 3) **Phantom/DYNAMIC/T-Power**
Selects the microphone powering type of the associated channel. NOTE: Use T-Powering only for T-Powered microphones.
- 4) **Mic/Line Channel Switch**
Selects the input level of its associated input connector.
- 5) **Phantom Voltage Selection**
Selects either 48V or 12V phantom voltage for the input channels.
- 6) **1 + 2 LINK**
Groups channels 1 and 2 as a stereo pair. ON selects a L/R stereo pair, MS selects a Mid-Side stereo pair. See Stereo Link for more information.
- 7) **RTN A and RTN B Level**
Adjusts the input sensitivity for the Return A and Return B signals. Useful for balancing levels when toggling between program and return audio.

Output Panel Descriptions

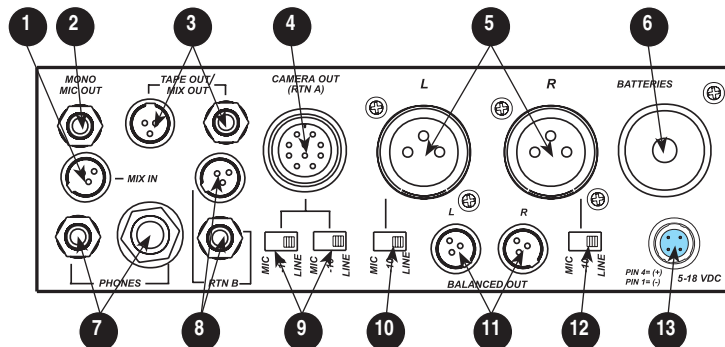

- 1) **Mix In**
Designed exclusively to link another 442, 302, MixPre, or MP-2 to the 442 for additional inputs. Signal is sent directly to the Output Stereo bus. Pin-1 = Ground, pin-2 = Left, pin-3 = Right. Shell of TA3 connector must be grounded to pin-1 to open connection.
- 2) **Mono Mic Out**
Unbalanced mono mic-level output on 1/8-inch female connector, designed to connect to wireless IFB transmitters or transcription recorders. Tip = Hot, sleeve = Ground.
- 3) **Tape Output(s) / Mix Out**
Unbalanced stereo outputs on 3.5 mm and TA3-type connectors. TA3, pin-1 = Ground, pin-2 = Left, pin-3 = Right. 1/8-inch, sleeve = Ground, tip = Left, ring = Right. Connect to the Mix In of another 442 for additional channels.
- 4) **Hirose Multi-Pin Output (Return A)**
Multi-pin connector includes second master output (on separate winding from XLR outputs) and unbalanced stereo Return A. See Block Diagram for pin configuration
- 5) **XLR Master Outputs**
Transformer-balanced outputs. Pin-1 = Ground; pin-2 = Hot (+); pin 3 = Cold (-). Unbalance by grounding pin-3 to pin-1 of the XLR connector.
- 6) **Battery Compartment**
Holds four AA batteries required for internal powering. Accepts Alkaline, Lithium, or NiHM rechargeable cells.
- 7) **Headphone Outputs**
1/4-inch and 3.5 mm stereo connectors, drive headphones from 8-2000 ohm impedances to required monitoring levels.
- 8) **Return B Inputs**
Unbalanced stereo TA3-type or 3.5 mm input connectors for Return B audio. TA3: pin-1 = Ground, pin-2 = Left, pin-3 = Right. 1/8-inch: sleeve = Ground, tip = Left, ring = Right.
- 9) **Multi-Pin Hirose Output Level**
Selects output level for the Hirose Multi-Pin Output to Mic, Tape, or Line Level.
- 10) **Left XLR Output Level**
Sets the nominal output level for the Left XLR Master Output to Mic, Tape (-10), or Line levels.
- 11) **TA3M-type Master Outputs**
Mic- or Line-level selectable in the Setup Menu. Pin-1 = Ground, pin-2 = Hot (+), pin-3 = Cold (-), float pin-3 to unbalance.
- 12) **Right XLR Output Level**
Sets the nominal output level for the Right XLR Master Output to Mic, Tape (-10), or Line levels.
- 13) **DC Input**
Accepts DC voltages from 5–18 V for mixer powering. 4-pin Hirose connector is wired pin-1 negative (-), pin-4 = positive (+). Ext DC is completely isolated (floating) from the rest of the circuitry. Early 442 models (s/n < 0303) use coaxial DC power connectors. Tip = (+) and sleeve = (-).

Input Channels

The inputs of the 442 consist of four, full-featured microphone preamplifiers. Each channel has a wide gain range to accommodate nearly all signal types. The 442 accepts signals ranging from low-sensitivity dynamic and ribbon microphones to medium-level wireless and condenser mic-level outputs, and to "hot" line-level signals.

442 input channels are transformer-balanced. The isolation characteristics of transformers are superior to other balancing techniques for the hostile and uncontrolled environments of field production. Transformers provide galvanic isolation from the driving source, meaning there is no direct electrical connection. Signals are "transformed" magnetically. The input transformers in the 442 use premium magnetic core material to achieve high signal handling capability (especially at low frequencies) while keeping distortion to a minimum. Because of their inherently high common mode impedance, transformers are unrivaled by any other type of input for common-mode noise rejection.

The XLR input connectors of the 442 can be used with either balanced or unbalanced connections. When unbalancing, ground pin-3 to pin-1. There is no change in gain between unbalanced and balanced connections into the 442.

Mic/Line Level Selection

 The Mic/Line switch is used to select the input level of the respective channel. The 442 has up to 84 dB of available gain from mic-input to line-output. When in the LINE position, the input channel sensitivity is reduced by 40 dB.

Gain (trim)



Like traditional mixing consoles, the 442's input sensitivity is set with the Gain (trim) potentiometer. With the Channel Fader set to unity gain (0 dB or 12 o'clock), make the appropriate adjustments with the Gain (trim) pot. Make coarse gain adjustments with the Gain (trim) pot during setup. Once the gain is set to the desired level, recess the Gain (trim) pot to hide it from the 442's mixing surface.

Channel Fader

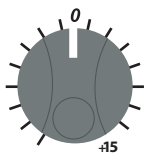

The Channel Fader is the primary level control used during mixing operation. Use the Channel Fader to make fine level adjustments during operation. The fader can be attenuated from Off (full counter-clockwise position) to +15 dB above the set Gain (Trim) level (full clockwise position).

Phantom and T- Microphone Powering

 This switch selects the type of power that will be applied to the adjacent input XLR. The 442 provides both Phantom and T-power on each channel respectively. If neither Phantom or T-power are required, for instance with dynamic microphones, it is best practice to turn Off microphone powering (DYN position). Phantom power can capacitively couple noise into the mic inputs with poor mic cables. The DYN (dynamic) position does not apply any voltage to the microphone input. Do not apply power to ribbon microphones, improperly wired cables can permanently damage the microphone.

Phantom Power

Phantom powering is a fixed DC voltage between 12 and 48 volts. This voltage is resistively applied to pin-2 and pin-3 of an XLR connector relative to pin-1. There is no voltage difference between the signal pins-2 and -3. Dynamic microphones will operate as normal when phantom power is applied to them.

The 442 can provide up to 10 mA to each input at 48 V, sufficient for the most power-hungry condenser microphones. Many phantom powered microphones do not require 48 V and can be properly powered with 12 V. When acceptable, use 12 V phantom to extend the 442's battery life. The phantom voltage level can be set to either 12 V or 48 V and is applied across all inputs where phantom power is selected.

T-Powering

T-powering is a microphone powering scheme used by several European condenser microphone manufacturers. Today, T-powered microphones are not as common as phantom powered microphones, but many are still in regular use. Unlike phantom power, T-power resistively applies 12 V between the signal pins -2 and -3. The 442 provides positive T-power on the three-pin XLR connector, pin-2 has +12 volts relative to pin-3. T-power can be selected for each input.

When using "red dot" T-powered microphones (reverse polarity T-power) use a polarity-reversing adapter on the input, otherwise damage to the microphone may occur.

Phantom and T-powering are not interchangeable. Use T-powering only for T-powered microphones.

High-Pass Filters



Each channel of the 442 has an adjustable high-pass filter. High-pass (or low-cut / low roll-off) filters are useful for removing excess low frequency energy from audio signals. Wind noise is a common unwanted low frequency signal that can be reduced with the use of a high-pass filter. For most audio applications engaging the high-pass filter is beneficial, because audio information below 100 Hz is rarely used, especially for speech reproduction.

The 442's high-pass filter circuit features an adjustable corner (-3 dB) frequency over a range from 80-240 Hz. Below 80 Hz, the filter's slope is 12 dB/octave. At higher corner frequency settings, the slope is 6 dB/octave. [See Specifications](#) The purpose for this compound slope is to give additional roll-off at the 80 Hz setting to reduce wind noise and low frequency rumble. The higher settings can be used to counteract the proximity effect of directional microphones where a more gentle slope is desired.

The 442's high-pass filter circuit is unique because of its placement before any electronic amplification. Most mixer's high-pass filter circuits are placed after the microphone preamplifier, where all of the high-energy low-frequency signals get amplified. By virtue of the 442's circuit cutting the low-frequency signals before amplifying, higher headroom is achieved in presence of signals with a lot of low-frequency energy.

When possible, attempt to equalize at the sound source with microphone selection, placement, windscreens, and onboard microphone filtering. Many microphones have on-board high pass filters, and the high-pass filters on the 442 can be used in conjunction with the microphone's filter to increase the filter's slope.

The filter can be removed from the circuit completely by moving the high-pass filter control to the full counter-clockwise (detented) position. The high-pass filter potentiometer can be adjusted easily and then recessed to hide it from the mixing surface.

Pan Controls



The Pan potentiometer controls the respective input's stereo image that is sent to the Stereo Output bus. The 442 uses constant loudness pan controls, meaning that the signal is 3 dB louder at the full-right or full-left positions relative to the center position. For most applications, the channel will be panned either hard-left, hard-right, or center; the 442 features excellent "off-attenuation" of the channels in the hard- left and right positions. The pan pot has a detent in the center position, and is calibrated at the Sound Devices factory for a maximum difference of +/- 0.1 dB between the left and right output in this position. The pan pot can be recessed to hide it from the mixing surface during normal operation.

Input Limiters



The Input Limiters act solely as "safety" limiters. Enabling the Output Limiters with the "LIM" switch, located on the front panel, will also enable the Input Limiters. *See Setup Menu to defeat the Channel Limiters entirely.*

In normal operation, with a properly set gain structure, the threshold of the Input Limiter will not be reached. In the event of extremely high input signal levels, such as in high SPL environments, the Input Limiter(s) will activate to prevent the input signal from clipping. Without Input Limiters, high signal conditions can overload the channel causing distortion.

Sound Devices recommends that the Input limiters be engaged at all times. The Input Limiter does not effect audio below the set threshold (just below clipping) in any way. When Input Channels 1 and 2 are linked as a stereo pair, the Input Limiters also are linked and perform the same gain reduction equally across the channels.

LIM LEDs

LIM



Each channel has an orange limiter LED which illuminates in proportion to the amount of limiting. If the channel limiter LED illuminates substantially, reduce the amount of gain applied to the channel by turning down the Gain (trim) pot.

Peak LEDs

PEAK



Each channel has its own red Peak LED to indicate that the signal is 3 dB below the clipping level of the respective channel. If the red Peak LED illuminates often, reduce the amount of gain applied to the respective channel by turning down the Gain (trim) pot.

Polarity Reversal - Channel 2



Engaging the Polarity Reverse Switch inverts the polarity of Channel 2. Polarity reversal is often used to quickly reverse the stereo field in MS recording. The normal position is OFF, with polarity reversal occurring when the switch is in the 0 position.

Do not change channel 2's polarity while recording, audible pops occur when the switch changes states.

Stereo Linking ON - Channels 1 and 2

When Stereo Link is set to ON, input channels 1 and 2 act as a single, stereo pair controlled by Channel 1's Fader. The Channel 1 Pan control acts as the balance control between left and right. Channel 2's Fader and Pan controls are disabled when Inputs are linked. Input 1 and 2's Gain (trim) pot and High-Pass Filters continue to act independently of each other. When linked, Channel 1 and 2's Input Limiters are also linked.

Stereo Link MS - Channels 1 and 2



When Stereo Link is set to MS, Channels 1 and 2 are linked as a MS pair. Input 1 is the Mid signal and Input 2 is the Side signal. The Channel 1 Pan Control functions as a left/right balance control for the matrixed MS signal. Channel 2's Fader and Pan controls are disabled. The Gain pots and High-Pass Filters continue to act independently of each other. The Gain (trim) pots on channels 1 and 2 can be used to vary the Mid and Side levels respectively. When linked, the Input Limiters on Inputs 1 and 2 are also linked.

PFL (Channel Solo Monitoring)



The momentary PFL switch temporarily solos the respective input in the headphone monitor. The signal is pre-fader, post-trim, post-high-pass, and post-limiter. At Factory Default, the left meter indicates the signal level of the soloed channel. PFL monitoring does not disrupt audio sent to the master outputs. PFL metering can be deactivated in the Setup Menu.

Outputs

The 442 is a two-bus mixer with several outputs, this is essential for multi-camera, multi-source productions. Because each input can be continuously panned from left to right, the mixer can be used with either two mono buses or with a single stereo bus.

Master Gain Control



The Master Gain Control adjusts the overall output level of the left and right outputs. The gain range of the Master Gain Control is from Off to +6 dB of gain. For most applications the Master control should be set at the unity gain (0) position. The master gain is on a pop-up knob so it can be set and hidden from the main surface. It is best practice to hide the Master Gain Control so that inadvertent adjustments are avoided.

Master Outputs - XLR and Hirose Multi-Pin

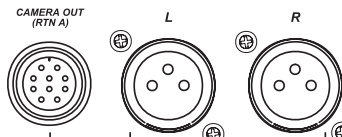

The master XLR and Hirose Multi-Pin outputs are transformer-balanced connections each driven from their own transformer windings for excellent isolation. Additionally, the outputs can independently be set to Line, Tape (-10 setting, 14 dB of attenuation from Line), or MIC Level (40 dB of attenuation from Line). The master outputs are capable of driving long lines.

The Hirose Multi-Pin connector also includes an unbalanced stereo Return A input for headphone monitoring.

Secondary Balanced Outputs



The TA3-type Balanced Outputs, located below the XLR Master Outputs are an additional set of master outputs. These outputs are impedance-balanced (pin-2 is driven and pin-3 is not) and can be used as either balanced or unbalanced outputs. The output level can be attenuated from Mic- to Line-levels via the Setup Menu. Factory default is Line-Level (+4 dBu nominal).

Tape Outputs (Mix Output)



Tape Outputs are typically used to interface with consumer inputs such as MiniDisc, DAT, and compact cassette recorders. The 442 offers two unbalanced tape level outputs available on a locking TA3M-type connector and a 3.5 mm female connector. These two connectors are resistively in parallel. Tape outputs are isolated from the main outputs, so any devices connected to these will have no effect on the master outputs.

Mono Mic Output



The Mono Mic Output is a sum of the left and right output channels. The 3.5 mm female connector outputs a mono, mic-level signal intended for connection with portable transcription recorders and wireless IFB transmitters.

Output Limiter

When the Input and Output Limiters are engaged, it is nearly impossible to clip (overload) the 442 mixer. Activate the 442 limiters by setting the front-panel "LIM" switch to either LINK or ON. [See Channel Limiter for more information on the Input Limiters.](#)

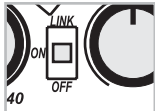

The Output Limiters prevent the output signal from exceeding the set limiter threshold. In the Setup Menu the Output Limiter Threshold can be set to any level from +4 dBu to +20 dBu in 1 dB increments. [See Setup Menu](#) At Factory Default, the mixer is set to limit the output signal peak levels to +20 dBu. This assures that the output of the 442 will not overload inputs that accept full line-level signals (+24 dBu peak).

The orange LIM LEDs, located at the end of the meter scale, illuminate in various intensities to represent the amount of limiting.

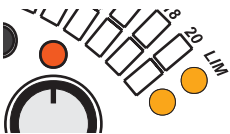

LINK vs ON

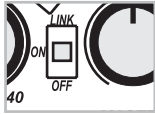

The Output Limiters can be linked as a stereo pair (LINK) or they can act as two independent limiters (ON). When linked, the limiters will perform the same gain reduction equally across both Left and Right channels. The LINK position is recommended when recording stereo program, so that level changes are identical for both channels. The ON position is recommended when using the 442 Outputs as two separate buses.

Mix Input (linking mixers)



The Mix In function allows two 442s to be linked together for applications requiring higher input channel counts. When 442s are linked together, all eight input channels will be present at the receiving mixer's (442 B) stereo outputs. The MIX IN connector is an unbalanced TA3M wired pin-1 = Ground, pin-2 = Left, pin-3 = Right. The shell of the TA3 connector must be grounded to pin-1 to open the connection.

To Link two 442s together:

1. Connect the TAPE OUT / MIX OUT of 442 A to the MIX IN of 442 B with a TA3F to TA3F cable (Sound Devices XL-1B optional accessory). This will send the stereo mix of 442 A directly to the stereo output bus of 442 B.

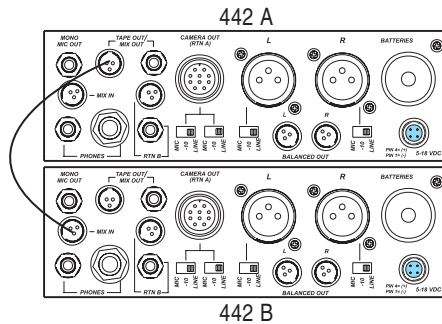

2. Monitor the stereo sum of all eight input channels from 442 B's ST headphone monitor.
3. Adjust the levels on each mixer accordingly.

The connector shell of the Mix In TA3 must be grounded to pin-1 of the connector to open the connection.

Metering

The 442 features a large 40-segment (20 per channel) LED output meter. The meter uses energy-efficient GaN LED's, which can be viewed in full sunlight. The 442 output meter is unaffected by shock, temperature, or humidity extremes. The microcontroller-based output meter provides a selection of ballistics and lighting intensities.

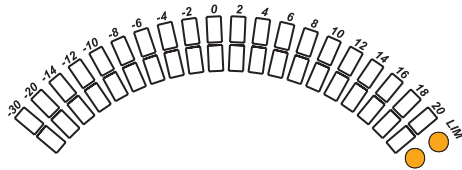

Meter Ballistics

The output meter can be set to display any of four types of meter ballistics - VU, Peak, a composite of VU and Peak, and a composite of VU with Peak hold. Change the meter ballistics at anytime by Pressing the PK/VU button. *See the Setup Menu for selections.*

VU

(Volume Units) Meter ballistics correspond closely to how the human ear perceives loudness. This provides a good visual indication of how loud a signal will be. In VU mode, the attack and decay of the meter signal is 300 mS. VU meters provide great visual indications of how loud a signal will be. However, VU meters provide poor information of actual signal peaks.

In VU mode, the front panel meter labeling is in volume units. VU meters are always referenced to an actual signal level in dBu, the 442 VU meter is referenced with 0 VU corresponding to 0 dBu at the Line-Level outputs. If needed, the reference level can be changed in the Setup Menu to +4 or +8 dBu.

Peak

Peak-reading ballistics correspond to actual signal peaks, but don't necessarily correspond to perceived signal loudness. The peak meter has an instantaneous attack and a slow decay to allow the user to visually monitor peak activity. Peak metering is useful when interconnecting to audio inputs on digital equipment. In the digital realm, signal overload can cause immediate distortion.

The peak meters front panel markings are calibrated in peak dBu level at the Line-Level outputs.

VU/Peak -

The 442 can simultaneously display VU and Peak level information. In this mode the perceived loudness (VU) is displayed on a bar graph, and the Peak signal on a dot above the VU. With this combination the user gets the best of both VU and Peak metering by seeing the "loudness" of the signal while observing peaks at the same time.

VU/Peak Hold

(firmware v. 3+ only) Similar to VU/Peak mode, this mode holds the peak level indication for several seconds before releasing. Peak Hold indicators are useful for metering in applications when an overload condition is unacceptable.

Ballistics Lock

(firmware v. 3+ only) Lock the selected meter ballistics setting by simultaneously pressing the Battery Check and Meter Brightness buttons. This setting is saved on power down.

Headphone Peak LED

Like the Channel Peak LEDs, the headphone circuit also has a peak overload indicator. This LED is very useful, since headphones can often overload before the mixer overloads. Monitoring without a visual indication of headphone clipping could mislead the operator into thinking that the output or return feeds are distorted. The Headphone Peak LED also doubles as a clip indicator for the stereo Return A and Return B signals. If any of the Return signals clip (after the Return gain stage), the Headphone Peak LED illuminates.

Headphone Monitoring

Headphone Source Selection

The rotary headphone source switch sets the audio source sent to headphones. The selections available are:

- Off** no signal
- L** left output only to both ears
- R** right output only to both ears
- M** summed (mono) left and right to both ears
- ST** stereo - left output to left ear and right output to right ear
- A** stereo Return A to headphones
- B** stereo Return B to headphones
- A|B** Return A (summed) to left ear, and Return B (summed) to right ear
- MS L** decoded MS Left to both ears
- MS R** decoded MS Right to both ears
- MS ST** decoded MS Stereo to headphones

Headphone Gain

Headphone gain is controlled by a pop up knob to remove it from the mixing surface.

The 442 can drive headphones to dangerously high volumes. Turn down the headphone gain control before selecting a headphone source to prevent accidental signal extremes.

Return A and B

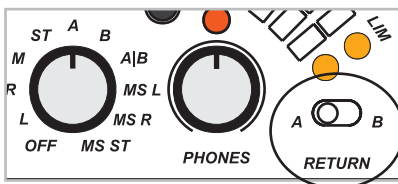

The Return monitor switch has two positions, A and B. When switched to the A position, Return A audio is sent to the headphones, taking precedence over the Headphone Source selection. Similarly, when toggled to the B position, Return B audio is sent to the headphones. This switch can change assignments performed in the Setup Menu.

Powering

The 442 can be powered from either internal batteries or externally via DC powering. The internal batteries can be used as either a primary power source or as a back-up in the event that external power is removed or depleted. The power switch selects the power source - either internal or external powering. There is a large enough power reserve to be able to switch back and forth from one source to the other without interruption of mixer signal.

The 442 is very power efficient and can run from four-AA alkaline batteries (without phantom) for approximately eight hours. As additional load is placed on the mixer, battery life is reduced.

Internal Powering

The 442 can be powered by AA-sized (LR6) batteries of various types. Lithium cells, alkaline, and NiMH rechargeable AA battery types are all popular batteries for internal AA powering. The 442 will achieve longest battery life with use of Lithium or NiMH batteries.

External Powering

The 442 can be powered from any DC voltage from 5 to 18 VDC. Pin-4 of the locking, Hirose connector is positive (+) and pin-1 is negative (-). The external DC supply is completely isolated (floating) from the rest of the mixer for easy and safe interconnection to other external audio gear.

Power Metering

The battery check button indicates battery voltages of internal and external power supplies. The left meter shows the internal battery voltage and the right meter shows the external battery voltage. Since many different battery types are available for external use, the external DC metering can be customized for a given battery in the Setup Menu.

Power Consumption

The 442 can vary in the amount of current it draws. Several functions of the 442 directly affect current draw in different ways. The following list highlights the larger current drawing functions (listed from highest to lowest current draw).

1. Microphone powering - the main source of extra 442 current draw. (*See Phantom Power*) 48 V Phantom can draw copious amounts of current out of the batteries depending on what model microphone is used. Two phantom powered microphones draw twice as much current as one. Microphones vary widely in their current draw depending on type and phantom voltage applied.
2. Output drive level - higher output drive levels into multiple, low-impedance inputs increases current draw.
3. Headphone output circuit - high headphone output levels increase current draw.

Experimentation is recommended to determine battery life for each individual setup and application.

Setting	High Voltage	LED Flash Point	Low Voltage	Power Source
	6.0	4.5	4.0	Internal batteries
1	13.0	11.5	11.0	12 V NiCad, NiMH. ← Factory Setting
2	17.0	11.5	11.0	Expanded range of setting #1
3	8.5	5.7	5.5	6 V NiMH, Li-ion, etc.
4	14.0	11.4	10.0	12 V Lead Acid
5	7.0	5.7	5.0	6 V Lead Acid
6	17.0	11.5	5.0	Full range of DC input, w/ cutoff for 12 V NiCad, etc.
7	16.3	13.5	12.5	14 V Li-ion rechargeables

Voltage Metering Chart

Tone Oscillator / Slate Microphone

A single 3-position switch controls both the tone oscillator and the slate microphone.



Tone Oscillator

Tone is used to set gain structure between the 442 and the next device in the signal path. The tone oscillator uses the locking position of the switch.

By default, the tone oscillator is set to output a 1 kHz sine wave at 0 dBu to the outputs (with the outputs set to Line Level). Tone is also sent at the same level to the direct outputs. In the Setup Menu, the tone frequency and output level can be changed. Also, the tone oscillator can be removed from the direct outputs or the tone switch can be defeated altogether.

The 442 oscillator contains a unique feature: the headphone output is attenuated by 20 dB when tone is activated. This ear-saving feature can be defeated in the Setup Menu.

With tone active, press the battery check button to cycle the left output by 20 dB (used to verify left vs. right output). Turn off the tone oscillator or press the battery check button again to stop the output cycling.

Slate Microphone

The slate microphone is used to notate scenes at the mixer location. Its audio performance is not suitable for critical recording applications; it should only be used for documenting scenes to tape. The slate mic uses the momentary switch position. In the Setup Menu, a one second 400 Hz tone can be set to precede the slate microphone.

The slate mic is sent to all outputs except the Direct Outs. In the Setup Menu, the slate mic can be disabled to prevent unintended activation.

The slate mic can function as a communication mic in addition to its normal Slate Mic function. This function is normally disabled and is turned on in the Setup Menu. In this mode, program audio at the right secondary-master TA3 connector is disabled. Instead, the audio from the slate mic appears when the RTN A/B switch is toggled. Normal program audio is unaffected. This function can be used in conjunction with a Sound Devices MM-1 to create a flexible communications system with a boom operator.

Accessing the Setup Menu

The 442 has 18 setup options (*See Setup charts*). Setups, while not typically changed during operation, are easily accessed from the front panel.

Enter the Setup Menu

To access the setup menu perform the following steps:

1. Turn off the mixer, if already on.
2. Depress and hold the Peak/VU selection switch while switching internal power on.

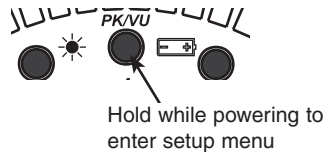

3. The setup mode is now enabled.

The mixer will not pass audio while in the Setup Menu.

In setup menu the left meter (L) position indicates the selected setup. The right meter (R) position indicates the values selected for the Setup. Use the PK/VU button advance from one setup to another. If you pass up the intended option, you must re-enter Set Up Mode since you cannot go backward, only forward when selecting individual setups.

To adjust values, the meter brightness button (left) and the battery check button (right) allow you to choose among setup values. Some setups have multiple values while others have only two values.

Example: Change the Tone Oscillator Frequency from the factory default (1 kHz) to 100 Hz.

1. Enter the setup menu by holding down the PK/VU button while powering the mixer.
2. Press the PK/VU button repeatedly until the left meter LED is at the -8 position (see Setup Menu).
3. To move among parameter values, press the brightness LED and battery check LED until the 100 Hz position is selected (-14 LED).
4. Press the PK/VU button until the meters dance. This sets the parameter into memory.

To save new values to memory, the PK/VU button must be repeatedly pressed until the last setup is reached. At that point the meters will scroll and the new values will be saved to memory.

User Default

(v.5+ firmware only) A memory location is available to store user-defined default settings. The user default is helpful to save a new “baseline” of settings different than the factory default settings.

User and Factory Default settings can be quickly recalled in the Setup Menu on 442 and 442N models running firmware v.5+. To save and recall the User Default. 442N specifics are shown in parenthesis.

1. Simultaneously press and hold the Brightness and Battery Check buttons while powering on the unit. The meters dance to indicate that a User Default setting has been saved. Release the Brightness and Battery Check buttons to continue with normal operation.

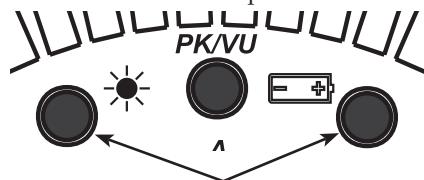

2. Recall the User Default by accessing the Setup Menu. With the 442 Off, press and hold the PK/VU button while powering on the mixer.
3. Access the Default Restore Setup Menu option by pressing the PK/ VU button repeatedly until the 18 (10) LED is illuminated on the left (top) meter.
4. The right (bottom) meter indicates the default setting to be restored. -30 (-30) is Off, no default setting will be restored when exiting the Setup Menu. -20 (-24) is the User Default, this will restore the setting that was saved when pressing the Brightness and Battery Check buttons while powering on the unit. -14 (-22) is Factory Default. Select -20 (-24) to restore the User Default.
5. Press the PK/VU button to exit the Setup Menu. Once the meters dance the User Default settings have been restored.

442 Nordic Information

The 442 Nordic (442N) is identical to the 442 except for its Nordic scale PPM meter.

Setup Menus

The Setup Menus vary slightly between the 442 and the 442N. To set the limiter threshold level an additional LED is illuminated for calculation. To find the limiter threshold value, consult the chart below.

Example: Change the Limiter Threshold from the factory default of +20 dBu to +14 dBu.

1. Enter the Setup Menu by holding down the PK/VU button while powering the mixer.
2. The Limiter Threshold setup is the first position (see Setup Menu).
3. To move among parameter values, press the brightness LED and battery check LED until the left meter illuminates "10" and the right meter illuminates "4".
4. Press the PK/VU button multiple times until the meters perform their scrolling dance. This sets the parameter into memory.

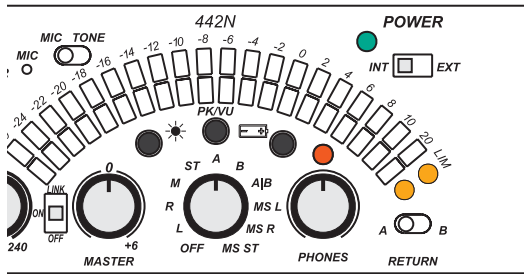

Level (in dBu)	Left (top) Meter	Right (bottom) Meter
+20	20	0
+19	10	10+8
+18	10	8
+17	10	8+6
+16	10	6
+15	10	6+4
+14	10	4
+13	10	4+2
+12	10	2
+11	10	2+0
+10	10	0
+9	10+8	0
+8	8	0
+7	8+6	0
+6	6	0
+5	6+4	0
+4	4	0

Setup Menu Firmware v 5.07

The chart below shows the available setups for the 442 and 442N. The flashing left (top) meter LED indicates the setup selected. The right meter LED indicates the available values, read from left to right.

L Meter Position 442(442N)	Setup	Description	Setting (value on R Meter)
-30 (-30)	Output Limiter Threshold Adjustment	Sets the output limiter threshold in dBu	1 dB increments from +4 dBu to +20 dBu at Line Level output
-20 (-24)	Input Limiter Defeat	Keeps input limiters OFF when the LIM switch is activated	-30 (-30) = OFF , -20 (-24) = ON
-14 (-22)	Balanced TA3 Output Level	Selects the nominal output level of the active-balanced TA3 outputs	-30 (-30) = Line-Level , -20 (-24) = Mic-Level
-12 (-20)	Direct Output Level	Selects the nominal output level of the active-balanced TA3 channel direct outputs	-30 (-30) = Line-Level , -20 (-24) = Mic-Level
-10 (-18)	Tone Oscillator Freq.	Selects the <i>f</i> of the sine wave setup tone	-30 (-30) = 1000 Hz , -20 (-24) = 400 Hz, -14 (-22) = 100 Hz
-8 (-16)	Tone Oscillator Level	Selects the output level of the tone oscillator in dBu	-30 (-30) = OFF , -20 (-24) = -20 dBu, -10 (-18) = -10 dBu, 1 dB increments to +8 dBu, 0 dBu = default.
-6 (-14)	Tone @ Direct Output	Selects whether tone is present on the Direct Outputs	-30 (-30) = ON , -20 (-24) = OFF
-4 (-12)	Slate Mic Toggle	Selects whether slate mic is activated when slate toggle switch is activated	-30 (-30) = ON , -20 (-24) = ON with 1 second of 400 Hz tone preceding, -14 (-22) = OFF
-2 (-10)	Comm Mic Function	Allows return A B toggle to be defeated and be reassigned to send slate mic signal to right TA3 output when toggled	-30 (-30) = OFF , -20 (-24) = ON
0 (-8)	PFL Level to Meter	Selects whether PFL level is indicated on the output meter	-30 (-30) = ON , -20 (-24) = OFF
2 (-6)	Monitor In Metering	Selects indication of monitor in signal level on the output meter (post monitor gain control) when the monitor toggle is activated	-30 (-30) = OFF , -20 (-24) = ON
4 (-4)	VU Reference Level	Selects 0 VU to dBu reference	-30 (-30) = 0 VU = 0 dBu , -20 (-24) = 0 VU = +4 dBu, -14 (-22) = 0 VU = +8 dBu, -12 (-20) = 0 VU/Peak = +1 dBu, -10 (-18) = 0 VU/Peak = +2 dBu, -8 (-16) = 0 VU/Peak = +3 dBu, -6 (-14) = 0 VU/Peak = +4 dBu, -4 (-12) = 0 VU/Peak = +5 dBu, -2 (-10) = 0 VU/Peak = +6 dBu, 0 (-8) = 0 VU/Peak = +7 dBu, 2 (-6) = 0 VU/0 Peak = +8 dBu
6 (-2)	Split-Ear Monitor A	Changes monitoring to hear program audio in one ear and monitor A in the other ear. Return A is summed and appears in R (right) headphone and L program appears in L (left) headphone. Is only active when Return toggle switch is activated.	-30 (-30) = OFF , -20 (-24) = ON
8 (0)	Split-Ear Monitor B	Changes monitoring to hear program audio in one ear and monitor B in the other ear. Return B is summed and appears in L (left) headphone and R program appears in R (right) headphone. Is only active when Return toggle switch is activated.	-30 (-30) = OFF , -20 (-24) = ON
10 (2)	Return Toggle Assignment	Allows the three-position monitor toggle to be assigned depending on preferred monitor connection used	-30 (-30) = A OFF B , -20(-24) = B OFF A, -14 (-22) = A OFF A, -12 (-20) = B OFF B
12 (4)	Headphone Attenuation with Tone	Reduces headphone level by 20 dB when the tone oscillator is activated	-30 (-30) = ON , -20 (-24) = OFF
14 (6)	External Battery Voltage Reference	Selects the Voltage range of the battery check function with external power. Also adjusts the flashing power LED voltage under external power.	1 = -30 (-30) , 2 = -20 (-24) , 3 = -14 (-22) , 4 = -12 (-20) , 5 = -10 (-18) , 6 = -8 (-16) , 7 = -6 (-14) see Powering for index.
16 (8)	Meter Ballistics Select	Selects the meter ballistics options available at the meter selection button.	-30 (-30) = VU PPM VU-PPMHold VU-PPM , -20 (-24) = PPM VU-PPMHold VU-PPM, -14 (-22) = VU VU-PPMHold VU-PPM, -12 (-20) = PPM VU-PPM, -10 (-18) = VU-PPM VU-PPMHold
18 (10)	Default Restore	Restores setup menu to the stored user default or to the factory default settings	-30 (-30) = OFF , -20 (-24) = User Default, -14 (-22) = Factory Default

Setup Menu Firmware v 3 & 4

The chart below shows the available setups for the 442 and 442N. The flashing left (top) meter LED indicates the setup selected. The right meter LED indicates the available values, read from left to right.

L Meter Position 442 (442N)	Setup	Description	Setting (value on R Meter)
-30 (-30)	Output Limiter Threshold Adjustment	Sets the output limiter threshold in dBu	1 dB increments from +4 dBu to +20 dBu at Line Level output
-20 (-24)	Input Limiter Defeat	Input limiters will remain OFF when the LIM switch is activated	-30 (-30) = OFF , -20 (-24) = ON
-14 (-22)	Balanced TA3 Output Level	Selects the nominal output level of the active-balanced TA3 outputs	-30 (-30) = Line-Level , -20 (-24) = Mic-Level
-12 (-20)	Direct Output Level	Selects the nominal output level of the active-balanced TA3 channel direct outputs	-30 (-30) Line-Level , -20 (-24) Mic-Level
-10 (-18)	Tone Oscillator Frequency	Selects the frequency of the sine wave setup tone	-30 (-30) = 1000 , -20 (-24) = 400, -14 (-22) = 100 Hz
-8 (-16)	Tone Oscillator Level	Selects the output level of the tone oscillator in dBu	-30 (-30) = OFF , -20 (-24) = -20 dBu, -10 (-18) = -10 dBu, 1 dB increments to +8 dBu, 0 dBu = default.
-6 (-14)	Tone @ Direct Output	Selects whether tone is present on the Direct Outputs	-30 (-30) = ON , -20 (-24) = OFF
-4 (-12)	Slate Mic Toggle	Selects whether slate mic is activated when slate toggle switch is activated	-30 (-30) = ON , -20 (-24) = ON with 1 second of 400 Hz tone preceding, -14 (-22) = OFF Note: tone not an option on firmware v3.
-2 (-10)	Comm Mic Function	Allows return A/B toggle to be defeated and be reassigned to send slate mic signal to right TA3 output when toggled	-30 (-30) = OFF , -20 (-24) = ON
0 (-8)	PFL Level to Meter	Selects whether PFL level is indicated on the output meter	-30 (-30) = ON , -20 (-24) = OFF
2 (-6)	Monitor In Metering	Selects indication of monitor in signal level on the output meter (post monitor gain control) when the monitor toggle is activated	-30 (-30) = OFF , -20 (-24) = ON
4 (-4)	VU Reference Level	Selects 0 VU to dBu reference	-30 (-30) = 0 dBu , -20 (-24) = +4 dBu, -14 (-22) = +8 dBu
6 (-2)	Split-Ear Monitor A	Changes monitoring to hear program audio in one ear and monitor A in the other ear. Return A is summed and appears in R (right) headphone and L program appears in L (left) headphone. Is only active when Return toggle switch is activated.	-30 (-30) = OFF , -20 (-24) = ON
8 (0)	Split-Ear Monitor B	Changes monitoring to hear program audio in one ear and monitor B in the other ear. Return B is summed and appears in L (left) headphone and R program appears in R (right) headphone. Is only active when Return toggle switch is activated.	-30 (-30) = OFF , -20 (-24) = ON
10 (2)	Return Toggle Assignment	Allows the three-position monitor toggle to be assigned depending on preferred monitor connection used	-30 (-30) = A OFF B , -20 (-24) = B OFF A, -14 (-22) = A OFF A, -12 (-20) = B OFF B
12 (4)	Headphone Attenuation with Tone	Reduces the headphone level by 20 dB when the tone oscillator is activated	-30 (-30) = ON , -20 (-24) = OFF
14 (6)	External Battery Voltage Reference	Selects the Voltage range of the battery check function with external power. Also adjusts the flashing power LED voltage under external power.	1 = -30 (-30), 2 = -20 (-24), 3 = -14 (-22), 4 = -12 (-20), 5 = -10 (-18), 6 = -8 (-16) see Powering for index.
16 (8)	Meter Ballistics Select	Selects the meter ballistics options available at the meter selection button.	-30 (-30) = PPM VU VU-PPMHold VU-PPM -20 (-24) = PPM VU-PPMHold VU-PPM -14 (-22) = VU VU-PPMHold VU-PPM -12 (-20) = PPM VU-PPM -10 (-18) = VU-PPM VU-PPMHold
18 (10)	Factory Default Restore	Enables the factory defaults to be reset	-30 (-30) = OFF , -20 (-24) = ON

Setup Menu Firmware v 2, (442 only)

The chart below is provided for users with the original production 442 firmware. Determine the firmware revision by viewing the meters when the unit is powered up. The left meter indicates the firmware version. The meters “dance” then an LED is lit. If the second LED from the left is lit, the unit has firmware version 2.

L Meter Position 442	Setup	Description	Setting (value on R Meter)
-30	Output Limiter Threshold Adjustment	Sets the output limiter threshold in dBu	1 dB increments from +4 dBu to +20 dBu at Line Level output
-20	Input Limiter Defeat	Allows the input limiters to remain OFF when the LIM switch is activated	-30 = OFF , -20 = ON
-14	Balanced TA3 Output Level	Selects the nominal output level of the active-balanced TA3 outputs	-30 = Line-Level , -20 = Aux-Level
-12	Direct Output Level	Selects the nominal output level of the active-balanced TA3 channel direct outputs	-30 = Line-Level , -20 = Aux-Level
-10	Tone Oscillator Frequency	Selects the frequency of the sine wave setup tone	-30 = 100, -20 = 400, -14 = 1000 Hz
-8	Tone Oscillator Level	Selects the output level of the tone oscillator in dBu	-30 = -20 dBu, -20 = -10 dBu, -14 = -8 dBu, -12 = 0 dBu , -10 = +4 dBu, -8 = +8 dBu, -6 = OFF
-6	Tone @ Direct Output	Selects whether tone is present on the Direct Outputs	-30 = OFF , -20 = ON
-4	Slate Mic Toggle	Selects whether slate mic is activated when slate toggle switch is activated	-30 = ON , -20 = OFF
-2	Comm Mic Function	Allows return A B toggle to be defeated and be reassigned to send slate mic signal to right TA3 output when toggled	-30 = OFF , -20 = ON
0	PFL Level to Meter	Selects whether PFL level is indicated on the output meter	-30 = OFF , -20 = ON
2	Monitor In Metering	Selects indication of monitor in signal level on the output meter (post monitor gain control) when the monitor toggle is activated	-30 = OFF , -20 = ON
4	VU Reference Level	Selects 0 VU to dBu reference	-30 = 0 dBu , -20 = +4 dBu, -14 = +8 dBu
6	Split-Ear Monitor A	Changes monitoring to hear program audio in one ear and monitor A in the other ear. Return A is summed and appears in R (right) headphone and L program appears in L (left) headphone. Is only active when Return toggle switch is activated.	-30 = OFF , -20 = ON
8	Split-Ear Monitor B	Changes monitoring to hear program audio in one ear and monitor B in the other ear. Return B is summed and appears in L (left) headphone and R program appears in R (right) headphone. Is only active when Return toggle switch is activated.	-30 = OFF , -20 = ON
10	Return Toggle Assignment	Allows the three-position monitor toggle to be assigned depending on preferred monitor connection used	-30 = A OFF B , -20 = B OFF A, -14 = A OFF A, -12 = B OFF B
12	Headphone Attenuation with Tone	Reduces the headphone level by 20 dB when the tone oscillator is activated	-30 = OFF, -20 = ON
14	External Battery Voltage Reference	Selects the Voltage range of the battery check function with external power. Also adjusts the flashing power LED voltage under external power.	1 = -30 , 2 = -20, 3 = -14, 4 = -12, 5 = -10, 6 = -8 see POWERING for index
16	Factory Default Restore	Returns the 442 to the factory defaults settings	-30 = OFF , -20 = Reset

Specifications

Measurement Settings (unless otherwise specified): Gain controls for the channel being measured at mid point, all other channel gains fully down; pan controls centered; low-cut off; inputs in 'MIC' position; outputs in LINE position. Mic input driven with 150 ohm source. Outputs measured with 100k ohm load. Temperature at 25°C

System

Dynamic Range	115 dB minimum (trim fully down)
Metering	40 segment, sunlight-viewable, selectable peak, VU, or peak (with or without peak hold) with VU ballistics, variable brightness

Analog Inputs

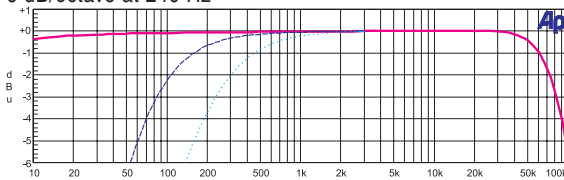
Frequency Response	20 Hz to 30 kHz, +0.2, -0.5 dB, -1 dB @ 5 Hz and 50 kHz typical
THD + Noise	0.007% typical (1 kHz, +4 dBu at line out) 0.09% max (50 Hz - 20 kHz, +18 dBu at line out, fader fully up)
Equivalent Input Noise	-126 dBu (-128 dBV) maximum. (22 Hz - 22 kHz bandwidth, flat filter, trim control fully up)
Input Type	XLR Mic: Transformer-balanced for use with <600 ohm mics XLR Line: Transformer-balanced for use with <2k ohm outputs RTN A,B (3.5 mm/TA3/Multi-pin): Unbalanced stereo for use with <2k ohm outputs Mix In: Unbalanced stereo for use with 442 Mix Out 1.8k ohm output
Input Impedance (ohms actual)	XLR Mic: 2k ohms XLR Line: 16k ohms RTN A,B (3.5 mm/TA3/Multi-pin): 20k ohms Mix In: 4.2k ohms
Input Clipping Level	0 dBu minimum (trim control fully down)
Maximum Input Level	XLR Mic: 0 dBu (0.78 Vrms) XLR Line: +40 dBu (80 Vrms) RTN A,B (3.5 mm/TA3/Multi-pin): +24 dBu (12.4 Vrms) Mix In: +6 dBu (1.5 Vrms)
Gain Matching	Mic/Line inputs: +/- 0.1 dB
Common Mode Rejection Ratio	120 dB minimum at 80 Hz, mic input 100 dB minimum at 10 kHz, mic input
High-Pass Filters	Sweepable 80 Hz to 240 Hz, 12 dB/oct at 80 Hz, 6 dB/octave at 240 Hz 
Mic Powering (each analog input selectable)	Dynamic (no power applied), 12 V Phantom - though 680 ohm resistors, 10 mA per mic available, 48 V Phantom - through 6.8k resistors, 10 mA per mic available, 12 V T-Power - through 180 ohm resistors, 10 mA per mic available
Mic/Line Input Limiters	Affects the output of the mic preamps only ('Trim' stage), +18 dBu threshold, 20:1 limiting ratio, 1 mS attack time, 200 mS release time.

Analog Outputs

Output Type	XLR Line: Transformer-balanced for use with >600 ohm inputs XLR -10: Transformer-balanced for use with >10k ohm inputs XLR Mic: Transformer-balanced for use with >600 ohm inputs Multipin Line: Transformer-balanced for use with >600 ohm inputs Multipin -10: Transformer-balanced for use with >10k ohm inputs Multipin Mic: Transformer-balanced for use with >600 ohm inputs TA3 Balanced Mic and Line: Impedance-balanced, pin-2 driven, for use with >3k ohm inputs TA3 Direct Outs Mic and Line: Impedance-balanced, pin-2 driven, for use with >3k ohm inputs Tape Outs (3.5 mm and TA3-type): Unbalanced, stereo, for use with >6k ohm inputs Mono Mic Out: Unbalanced, mono, for use with >600 ohm inputs Headphones (3.5 mm and 1/4"): Unbalanced, stereo, for use with 8-2k ohm headphones
Output Impedance (ohms actual)	XLR: 85 ohms at Line setting, 3.2k ohms at -10 setting, 150 ohms at Mic setting Multipin: 85 ohms at Line setting, 3.2k ohms at -10 setting, 150 ohms at Mic setting TA3 Balanced Outs: 1k ohms at Mic and Line settings TA3 Direct Outs: 1k ohms at Mic and Line settings Tape Outs (3.5 mm and TA3-type): 1.8k ohms Mono Mic Out: 150 ohms Headphones (3.5 mm and 1/4"): 200 ohms
Line Output Clipping Level (1% THD)	20 dBu minimum 18 dBu minimum w/600 ohm load
Maximum Output Level	Line (XLR, Multipin, TA3 Balanced and Direct Outs): +20 dBu (7.8 Vrms) -10 (XLR, Multipin): +6 dBu (1.5 V rms) Mic (XLR, Multipin, TA3 Balanced and Direct Outs): -20 dBu (0.078 Vrms) Tape Outs (3.5 mm and TA3-type): +6 dBu (1.5 Vrms) Mono Mic Out: +6 dBu (1.5 Vrms) Headphones (3.5 mm and 1/4"): +20 dBu (7.8 Vrms)
Output Noise	-100 dBu (-102 dBV) maximum (22 Hz - 22 kHz bandwidth, flat filter, master gain fully up, faders fully down)
Output Limiters	Affects the outputs of the mixer. Threshold selectable from +4 dBu to +20 dBu, 1 dB steps, 20:1 limiting ratio, 1 mS attack time, 200 mS release time.

Maximum Output
Typical (Trim, Fader, Master, Phones, RTN A, RTN B fully up)

	XLR Input MIC Level	XLR Input LINE Level	RTN A, B
XLR, Multi-pin Outs @ LINE	81 dB	41 dB	-
XLR, Multi-pin Outs @ -10	67 dB	27 dB	-
XLR, Multi-pin Outs @ MIC	41 dB	1 dB	-
Balanced TA3-type Outs @ LINE	81 dB	41 dB	-
Balanced TA3-type Outs @ MIC	41 dB	1 dB	-
Tape Out, TA3-type and 1/8"	67 dB	27 dB	-
Mono Mic Out	41 dB	1 dB	-
Headphones, 1/4" and 1/8"	101 dB	81 dB	30 dB

Power

Power supply (batteries) Internal ± 16 V (bi-polar) regulated audio rails, 3.2-8 V range internal batteries

Power supply (external) Isolated (floating) external DC input jack, 5-18 V
Locking 4-pin Hirose connector, pin-4 = (+), pin-1 = (-),
Use gold Hirose #HR10A-7P-4P (DigiKey# HR110-ND) or silver Hirose #HR10-7P-4P (DigiKey# HR100-ND) for locking mating DC connector.

Environmental

Operation and Storage Operating: -20°C to 60°C, 0 to 95% relative humidity; (non-condensing)
Storage: -40°C to 85°C

Other

Tone Oscillator Frequency: Setup Menu selectable 100 Hz, 400 Hz, 1000 Hz
Output Level: Variable output from -20 to +8 dBu

Dimensions and Weight

Size 53 mm x 165 mm x 279 mm (H x W x D)
2.1" x 6.5 x 11"

Weight unpackaged: 2.0 kg, (4 lbs 5 oz.) with four AA batteries

Block Diagram - Inputs and Outputs

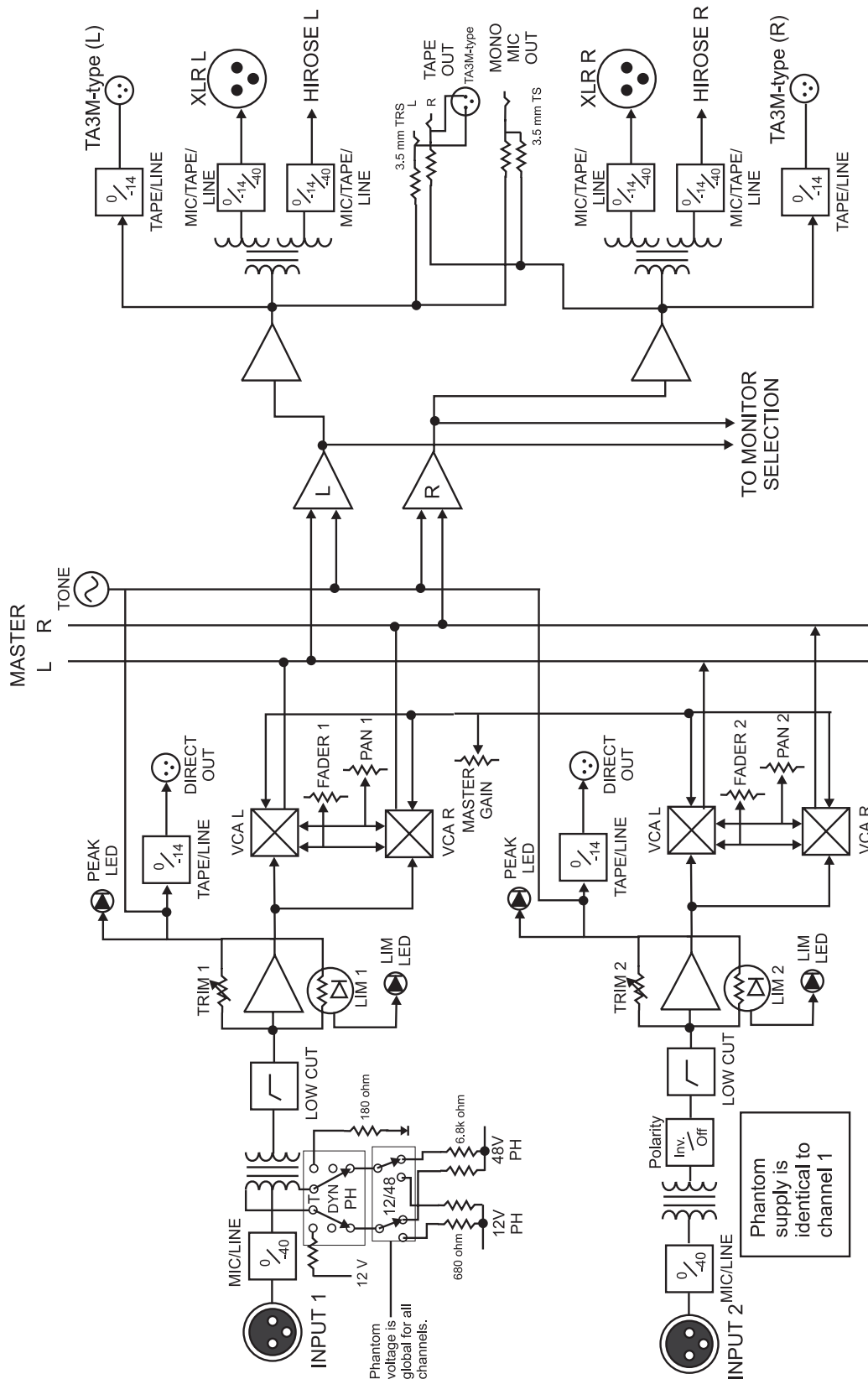

Block Diagram - Monitoring

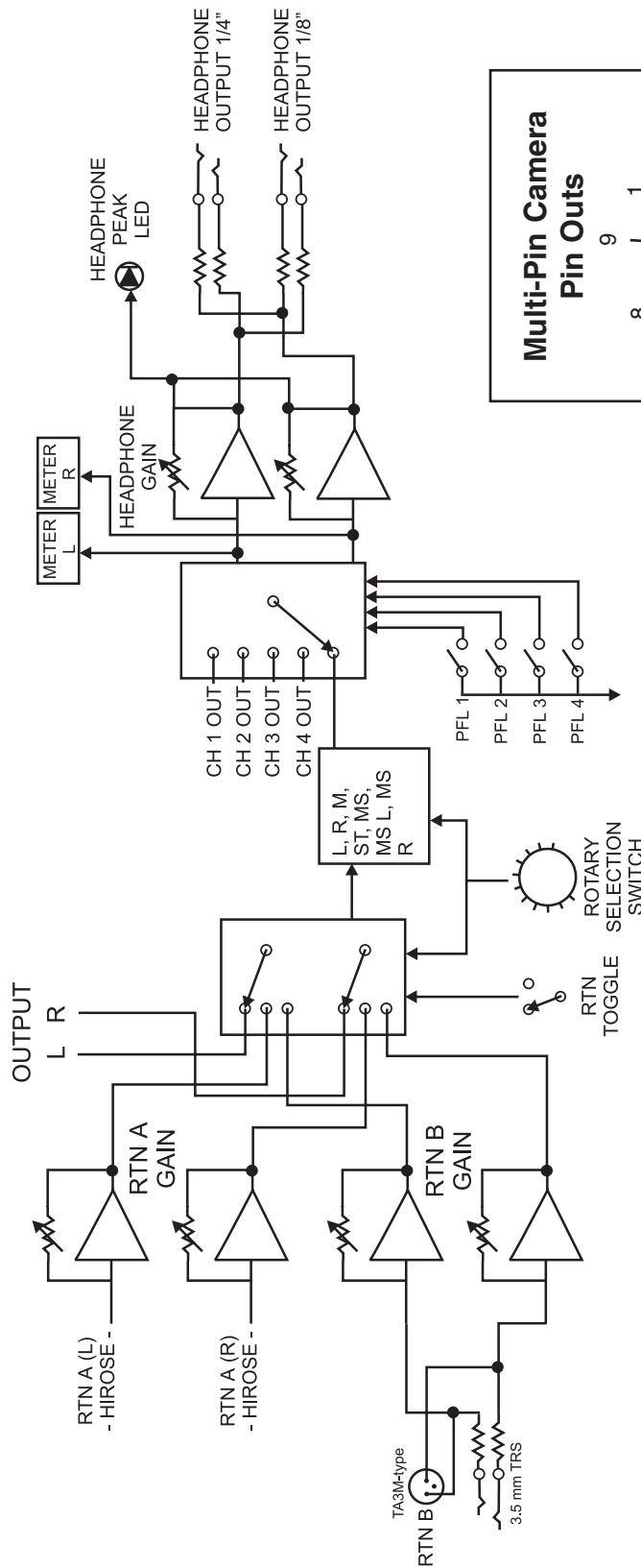



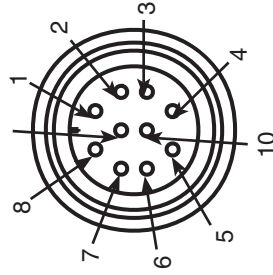



Multi-Pin Camera Pin Outs



- 1... L (+) output
 - 2... L (-) output
 - 3... R (+) output
 - 4... R (-) output
 - 5... R (+) return A
 - 6... n/c
 - 7... L (+) return A
 - 8... n/c
 - 9... ground
 - 10... ground
- Mates with Hirose RM15TPD-10P (71) connector.

Accessories

Several high-value accessories are available for the 442 mixer, including a carry-case, cables, and power accessories. For a full list of Sound Devices products and accessories, visit our web site www.sounddevices.com/products.

<p>CS-4</p> 	<p>Production case with high-quality strap for use with 442 Field Mixer with integrated accessory compartment and NP-type battery compartment. Built for Sound Devices by CamRade..</p>
<p>CS-W</p> 	<p>The CS-W is a removable accessory case for the CS-4 Production Case. The CS-W is designed to hold wireless transmitters and receivers and provides the appropriate cable routing for interconnection of wireless, mixers, and recorders. Built for Sound Devices by CamRade.</p>
<p>XL-H</p>	<p>Bare Hirose connector, (Hirose p/n HR10-7P-4P) to mate with locking 4-pin DC power jack.</p>
<p>XL-K1</p> 	<p>Knob accessory kit for 442. Replaces the fader knobs with visual and tactile position-indicating knobs. Kit of four, 2-black 2-gray. Includes colored inserts. 442-specific.</p>
<p>XL-K2</p> 	<p>Knob accessory kit for 442. Replaces the fader knobs with visual and tactile position-indicating knobs. Kit of four, 2-black 2-gray. Includes colored inserts. 442-specific.</p>
<p>XL-NPH</p> 	<p>NP-type battery cup with 12-inch cable with Hirose 4-pin locking power jack at equipment end. For use with 302, 442N, 442, and MixPre.</p>
<p>XL-WPH2</p> 	<p>Universal, in-line AC-to-DC power supply with detachable IEC power cord. Input: 100–240, 50/60 Hz; output 12 VDC, 30 W on Hirose 4-pin connector..</p>
<p>XL-1 / XL-1A</p>	<p>TA3-F to TA3-F Interconnection cables for 302-to-302 and 302-to-442 linking; 24-inch (XL-1A package of 2).</p>
<p>XL-2</p>	<p>TA3-F to XLR-M (male) cable; 25-inch; connects balanced TA3 to XLR inputs; package of two cables</p>
<p>XL-2F</p>	<p>TA3-F to XLR-F (female) cable; 25-inch; connects balanced TA3 to XLR inputs; package of two cables; 442-specific.</p>
<p>XL-3</p>	<p>3.5 mm to TA3-F link cable for MixPre/MP-2 Tape Output to 302 Mix In; 20-inch.</p>
<p>XL-4</p>	<p>Bag of four (4) TA3-F-type connectors.</p>
<p>XL-10</p>	<p>Hirose 10-pin to two-XLR (balanced L/R) and 3.5 mm plug (442 Stereo Return A) breakout cable; includes in-line 20-foot extension cable; 442-specific.</p>

CE Declaration of Conformity

According to ISO/IEC Guide 22

Sound Devices, LLC
300 Wengel Drive
Reedsburg, WI 53959 USA

declares that the product, 442 Production Field Mixer is in conformity with and passes:

EN55103-1, 1997	EMC-product family standard for audio, video, audio-visual and entertainment lighting control apparatus for professional use. Part 1: Emissions
EN55103-2, 1997	EMC-product family standard for audio, video, audio-visual and entertainment lighting control apparatus for professional use. Part 2: Immunity
EN55103-1 Phenomena 2, 3, 1997	Magnetic emissions at 1 meter 50 Hz – 50 kHz
EN55103-2 Phenomena 3, 1997	Magnetic immunity 50 Hz to 10 kHz
EN61000-4-2 (2001)/ IEC61000-4-2 (2001)	ESD, ± 4 kV contact, ± 8 kV air discharge
EN61000-4-3 (2001)/ IEC1000-4-3 (2001)	Radiated RF immunity, 10 V/m, 80% 1 kHz amplitude modulation
EN61000-4-4 (2001)/ IEC61000-4-4 (2001)	AC power ports: EFT Burst, I/O lines, ± 0.25 kV to ± 1.0 kV, power line ± 0.5 kV – ± 1 kV
EN61000-4-4 (2001)/ IEC61000-4-4 (2001)	EFT Burst, I/O lines, ± 0.25 kV to ± 1.0 kV, power line ± 0.5 kV – ± 1 kV
EN61000-4-5 (2001)/ IEC61000-4-5 (2001)	Surge ± 1 kV differential mode (line-to-line), ± 2 kV common mode (line-to-ground)
EN61000-4-6 (2001)/ IEC61000-4-6 (2001)	Conducted RF immunity, 3 V, 80% @1 kHz amplitude modulation
IEC61000-4-11(2001)	Voltage dips and short interruptions at test voltage level: 0% V unominal @ 70% V unominal @ 25 period

Tested by L. S. Compliance, Inc. Cedarburg, Wisconsin
December 16, 2001



Matthew Anderson
Director of Engineering
Sound Devices, LLC

Warranty and Technical Support

Warranty

Sound Devices, LLC warrants the 442 Production Mixer against defects in materials and workmanship for a period of ONE (1) year from date of original retail purchase. This is a non-transferable warranty that extends only to the original purchaser. Sound Devices, LLC will repair or replace the product at its discretion at no charge. Warranty claims due to severe service conditions will be addressed on an individual basis. THE WARRANTY AND REMEDIES SET FORTH ABOVE ARE EXCLUSIVE. SOUND DEVICES, LLC DISCLAIMS ALL OTHER WARRANTIES, EXPRESS OR IMPLIED, INCLUDING WARRANTIES OF MERCHANTABILITY AND FITNESS FOR A PARTICULAR PURPOSE. SOUND DEVICES, LLC IS NOT RESPONSIBLE FOR SPECIAL, INCIDENTAL, OR CONSEQUENTIAL DAMAGES ARISING FROM ANY BREACH OF WARRANTY OR UNDER ANY OTHER LEGAL THEORY. Because some jurisdictions do not permit the exclusion or limitations set forth above, they may not apply in all cases.

For all service, including warranty repair, please contact Sound Devices for an RMA number and send the 442, along with proof of purchase date to:

Sound Devices, LLC
Service Repair RMA # XXXX
300 Wengel Drive
Reedsburg, WI 53959 USA

Technical Support / Bug Reports

For technical support and bug reporting on all Sound Devices products contact:

Sound Devices, LLC
E-mail: support@sounddevices.com
web: www.sounddevices.com/contact_support.htm
Telephone: +1 (608) 524-0625 / Toll-Free in the U.S.A.: (800) 505-0625
Fax: +1 (608) 524-0655

Sound Devices hosts a support forum for 7-Series recorders. The URL is:

www.sounddevicessupport.com

FCC Statement

This device has been tested and found to comply with the limits for a class B digital device, pursuant to part 15 of the FCC rules. These limits are designed to provide reasonable protection against harmful interference in a residential installation. This equipment generates, uses, and can radiate radio frequency energy and, if not installed and used in accordance with the instructions, may cause harmful interference to radio communications. However, there is no guarantee that interference will not occur in a particular installation.

SOUND DEVICES